



RIRS 400-700 H EKO 3.0

EN MOUNTING AND INSTALLATION INSTRUCTION

 **SALDA**

www.salda.it

1. CONTENT

2.SYMBOLS AND MARKING	3
3.SAFETY INSTRUCTIONS AND PRECAUTIONS	4
4.INFORMATION ABOUT THE PRODUCT	5
4.1. DESCRIPTION	5
4.2. DIMENSIONS AND WEIGHT	5
4.3. TECHNICAL DATA	6
4.4. OPERATING CONDITIONS	7
4.5. STANDARD PACKAGE OF COMPONENTS	7
4.6. DESCRIPTION OF COMPONENTS	7
5. INSTALATION	8
5.1. RECEPTION OF GOODS	8
5.2. TRANSPORTATION AND STORAGE	8
5.3. UNPACKING	8
5.4.PIPING AND INSTRUMENTATION DIAGRAM	9
5.5. MOUNTING	10
5.5.1. UNIT PLACING AND MOUNTING POSITIONING REQUIREMENTS	10
5.5.2. FLOOR MOUNTING	10
5.6. CONNECTION OF THE AIR DUCT	11
5.7.CONNECTION OF THE UNIT TO ELECTRIC NETWORK	11
5.8. START-UP RECOMMENDATIONS	11
5.8.1. SYSTEM PROTECTION	11
5.8.2.PRE-STARTUP RECOMENDATIONS OF THE UNIT (IN THE PRESENCE OF THE ENDUSER)	12
6. MAINTENANCE	13
6.1. SAFETY INSTRUCTION	13
6.2.GENERAL RECOMMENDATIONS FOR VENTILATION SYSTEM MAINTENANCE	13
6.3. COVER OPENING	13
6.4. FILTERS MAINTENANCE	14
6.5. ROTOR MAINTENANCE MAINTENANCE	14
6.6. FANS MAINTENANCE	14
6.7. HEATER MAINTENANCE	15
6.8. CONTROL BOARD MAINTENANCE	15
7. CONTROL	16
7.1. DEVICE CONTROL	16
7.2. DEVICE FUNCTIONS	16
8. ACCESSORIES	17
8.1. CONNECTION OF ACCESSORIES	18
8.1.1.FIRE PROTECTION SIGNAL INPUT (FIRE PROTECTION INPUT (NC))	18
8.1.2.EXTERNAL CO2 /PRESSURE SENSORS	19
8.1.3.ROOM CO2 TRANSMITTER INSTALLATION RECOMMENDATION	19
8.1.4.CO2 CONCENTRATION ACCORDING TO PETTENKOFER LIMIT	19
8.1.5.CONNECTION OF SUPPLY AND EXTRACT AIR DAMPERS	20
8.1.6.CONNECTION OF REMOTE CONTROL PANEL OR MODBUS	20
8.1.7.WATER HEATER CIRCULATION PUMP AND VALVE ACTUATOR	20
8.1.8.RECOMMENDED SCHEME FOR CONNECTION OF INTERNAL AND EXTERNAL COMPONENTS	22
9.POSSIBLE FAULTS AND TROUBLESHOOTING	24
10.ECODESIGN DATA TABLE	25
11.DECLARATION OF CONFIMITY	26
12. WARRANTY	27
12.1. LIMITED WARRANTY COUPON	27

2. SYMBOLS AND MARKING



Warning – pay attention



Additional information

Apply the auxiliary label on the unit (on an easily accessible location) or on the dashed location of the technical manual in order to keep the important information about the unit.

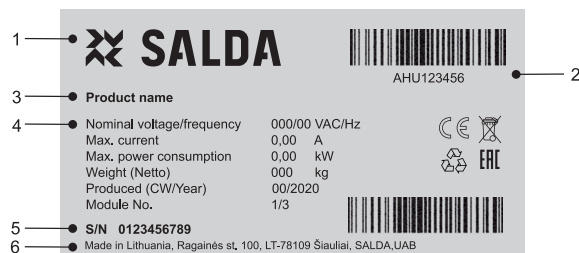

Figure 2.1. Technical label

1 - Logo; 2 - Product code (SKU); 3 - Product name; 4 - Technical data; 5 - Serial number; 6 - Production place.



Figure 2.2. Indication for duct connection.

ODA - outdoor air; SUP - supply air; ETA - extract air; EHA - exhaust air.

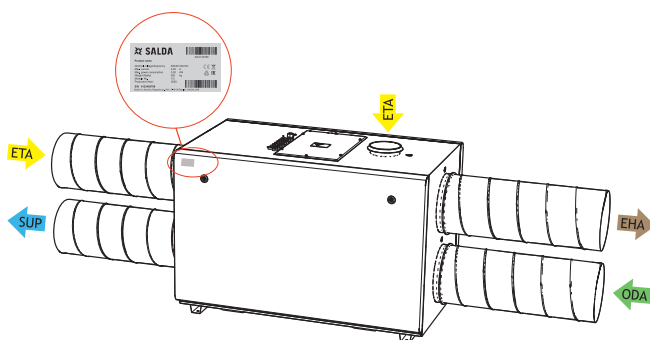

Figure 2.3. Technical label place and air duct indication (left side)

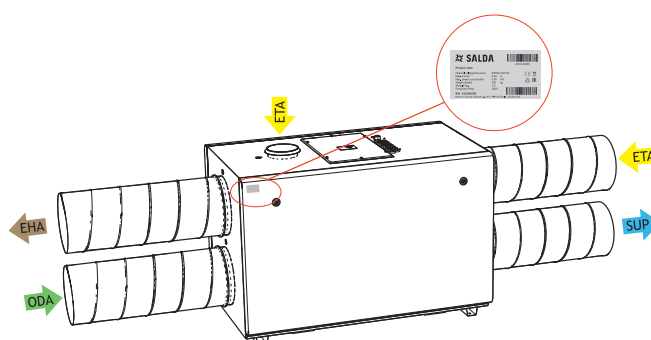

Figure 2.4. Technical label place and air duct indication (right side)



NOTE. Ducts are not the part of the unit.

3. SAFETY INSTRUCTIONS AND PRECAUTIONS

Read these instructions very carefully before installing and using this equipment. Installation, connection and maintenance should be carried out by a qualified technician and in accordance with the local regulations and legislation.

The company shall take no responsibility for the injuries or damaged property if the safety requirements are not followed or the device is modified without the permission of the manufacturer.

Main safety rules

Danger

- Before carrying out any electrical or maintenance works, make sure that the device is disconnected from the mains and all moving parts of the device have stopped.
 - Make sure that the fans are not accessible through air ducts or branch openings.
 - If any liquids on electric parts or connections that bear voltage are noticed, stop the operation of the device.
 - Do not plug the device into the mains that differ from the one indicated on the label or on the housing.
 - Voltage of the mains should comply with the electro technical parameters indicated on the label.
 - The device should be earthed in accordance with the regulations on the installation of electric devices. Turning on and using unearthed device is not allowed. Follow the requirements specified on the device's labels that indicate danger.
-

Warnings

- Connection of electricity and maintenance of the device should be performed by the qualified personnel only and in accordance with the manufacturer's instructions and safety requirements.
 - In order to reduce the risk during installation and maintenance, suitable protective clothing must be worn.
 - Beware of sharp angles while carrying out installation and maintenance works.
 - Do not touch heating elements until they haven't cooled down.
 - Some devices are heavy, you should be very careful while transporting and installing them. Use suitable lifting equipment.
 - When connecting electricity to the mains, a circuit breaker of suitable size must be used.
-

Warning!

- If the device is installed in a cold environment, make sure that all connections and tubes are properly isolated. Intake and discharge air ducts should be isolated in all cases.
 - Openings of the ducts should be covered during transportation and installation.
 - Make sure not to damage the heater when connecting the piping of the water heater. For tightening up, use a wrench/spanner.
-

Before starting up the device

- make sure, that there are no strange objects inside;
 - manually check fans to make sure they are not stuck or blocked;
 - if rotary heat exchanger is installed in the device, make sure that it is not stuck or blocked;
 - check the earthing;
 - make sure that all components and accessories are connected in accordance with the wiring diagram or provided instructions.
-

4. INFORMATION ABOUT THE PRODUCT

4.1. DESCRIPTION

RIRS H EKO 3.0 is a residential air handling unit with a high efficiency (up to 73 %) rotor heat exchanger. The unit supplies ventilation in home and takes the heat from exhaust air. AHU complies with ErP 2018 requirements. The unit is operated by a separate remote control panel or through separate MB-Gateway by PC. Remote control panel and MB-Gateway are optional and not included in standard package.



Not suitable for operation in pools, saunas and other similar premises.

4.2. DIMENSIONS AND WEIGHT

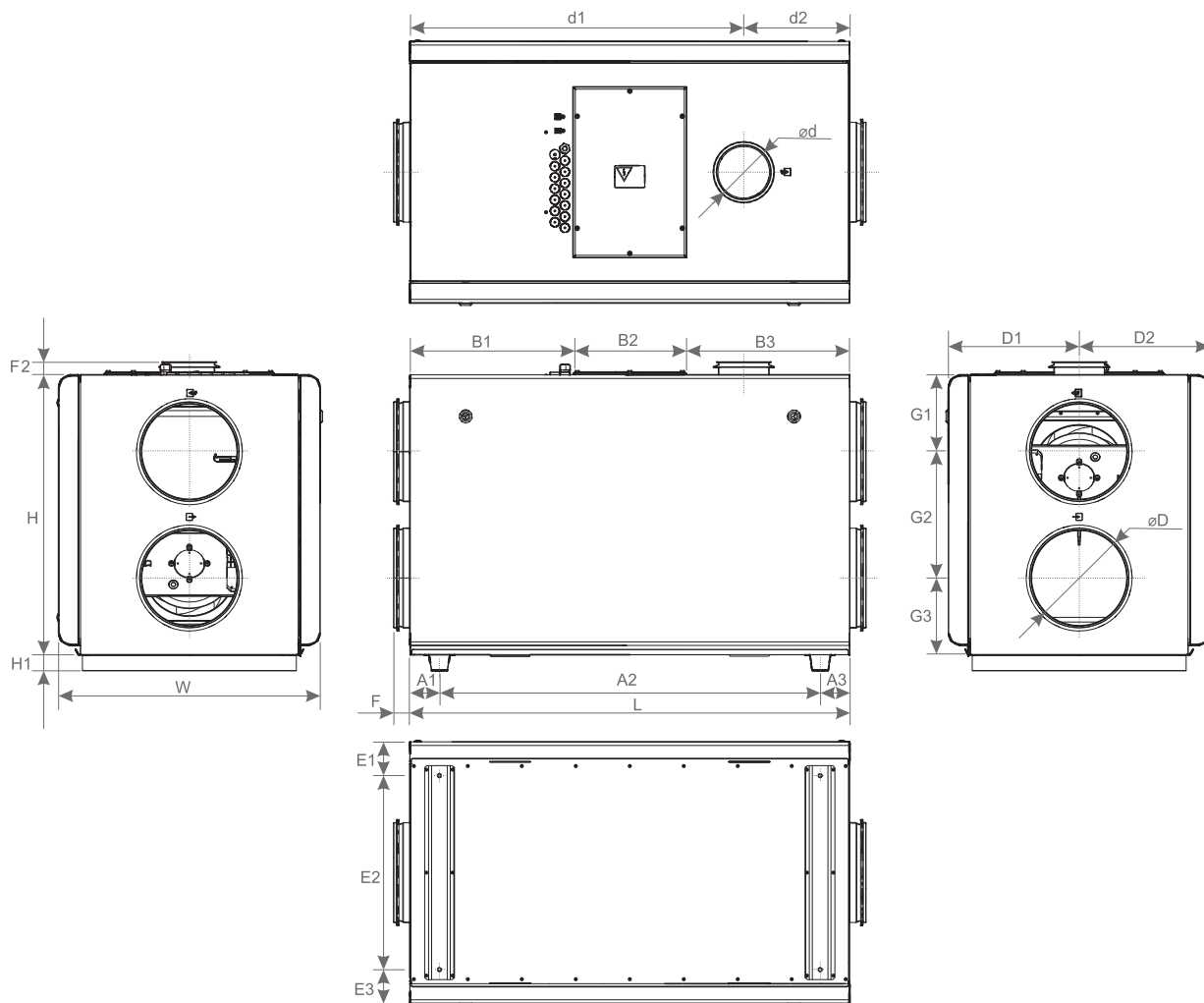

RIRS EKO 3.0		400 HEL	400 HER	400 HWL	400 HWR	700 HEL	700 HER	700 HWL	700 HWR
L	[mm]	1000	1000	1000	1000	1100	1100	1100	1100
W	[mm]	560	560	560	560	655	655	655	655
H	[mm]	610	610	610	610	700	700	700	700
D	[mm]	200	200	200	200	250	250	250	250
H1	[mm]	40	40	40	40	40	40	40	40
F2	[mm]	32	32	32	32	32	32	32	32
F	[mm]	31	31	31	31	41	41	41	41
d	[mm]	125	125	125	125	125	125	125	125
A1	[mm]	72	72	72	72	74	74	74	74
A2	[mm]	856	856	856	856	952	952	952	952
A3	[mm]	72	72	72	72	74	74	74	74
E1	[mm]	85	85	85	85	85	85	85	85
E2	[mm]	390	390	390	390	485	485	485	485
E3	[mm]	85	85	85	85	85	85	85	85
B1	[mm]	385	330	385	330	408	265	408	265
B2	[mm]	285	285	285	285	284	835	284	835
B3	[mm]	330	385	330	385	408	408	408	408
d1	[mm]	753	247	753	247	835	265	835	265
d2	[mm]	247	753	247	753	265	835	265	835
D1	[mm]	280	280	280	280	327	327	327	327
D2	[mm]	280	280	280	280	327	327	327	327
G1	[mm]	175	175	175	175	192	192	192	192
G2	[mm]	267	267	267	267	316	316	316	316
G3	[mm]	168	168	168	168	192	192	192	192
WEIGHT	[kg]	78	78	76	76	96	96	94	94

4.3. TECHNICAL DATA

RIRS EKO 3.0		400 HE	400 HW	700 HE	700 HW
Exhaust air fan					
phase/voltage	[50 Hz/VAC]	1/230	1/230	1/230	1/230
power/current	[kW/A]	0,09 / 0,75	0,09 / 0,75	0,17 / 1,4	0,17 / 1,4
speed	[min ⁻¹]	3200	3200	3230	3230
control input	[VDC]	0-10	0-10	0-10	0-10
protection class		IP-54	IP54	IP-54	IP-54
Supply air fan					
phase/voltage	[50 Hz/VAC]	1/230	1/230	1/230	1/230
power/current	[kW/A]	0,09 / 0,75	0,09 / 0,75	0,17 / 1,4	0,17 / 1,4
speed	[min ⁻¹]	3200	3200	3230	3230
control input	[VDC]	0-10	0-10	0-10	0-10
protection class		IP-54	IP54	IP-54	IP-54
Integrated electrical heater	[kW]	1,2	-	2,0	-
Total power/current consumption	[kW/A]	1,38 / 6,80	0,18 / 1,60	2,34 / 11,60	0,34 / 2,90
Automatic control integrated		PRV	PRV	PRV	PRV
Insulation of walls	[mm]	50	50	50	50
Exhaust air filter (class, dimensions LxWxH)	[mm]	MPL 450x170x46 ePM1-70	MPL 450x170x46 ePM1-70	MPL 545x260x46 ePM1-70	MPL 545x260x46 ePM1-70
Supply air filter (class, dimensions LxWxH)	[mm]	MPL 450x170x46 ePM10-55	MPL 450x170x46 ePM10-55	MPL 545x260x46 ePM10-55	MPL 545x260x46 ePM10-55
Device protection class		IP 34	IP 34	IP 34	IP 34

Acoustic data: check the product page on www.salda.it



Not suitable for installation in living rooms: additional noise insulation required.

4.4. OPERATING CONDITIONS

RIRS EKO 3.0	400 HEL	400 HER	400 HWL	400 HWR	700 HEL	700 HER	700 HWL	700 HWR
Minimum outdoor air temperature	-23 °C	-23 °C	-23 °C	-23 °C	-23 °C	-23 °C	-23 °C	-23 °C
Maximum outdoor air temperature	+40 °C	+40 °C	+40 °C	+40 °C	+40 °C	+40 °C	+40 °C	+40 °C
Minimum extracted air temperature	+15 °C	+15 °C	+15 °C	+15 °C	+15 °C	+15 °C	+15 °C	+15 °C
Maximum extracted air temperature	+40 °C	+40 °C	+40 °C	+40 °C	+40 °C	+40 °C	+40 °C	+40 °C
Maximum extracted air relative humidity	60 %	60 %	60 %	60 %	60 %	60 %	60 %	60 %
Minimum ambient air temperature	+5 °C	+5 °C	+5 °C	+5 °C	+5 °C	+5 °C	+5 °C	+5 °C
Maximum ambient air temperature	+40 °C	+40 °C	+40 °C	+40 °C	+40 °C	+40 °C	+40 °C	+40 °C
Installation	indoor	indoor	indoor	indoor	indoor	indoor	indoor	indoor

4.5. STANDARD PACKAGE OF COMPONENTS

RIRS EKO 3.0	400 HEL	400 HER	400 HWL	400 HWR	700 HEL	700 HER	700 HWL	700 HWR
Key 291103	1	1	1	1	1	1	1	1

4.6. DESCRIPTION OF COMPONENTS

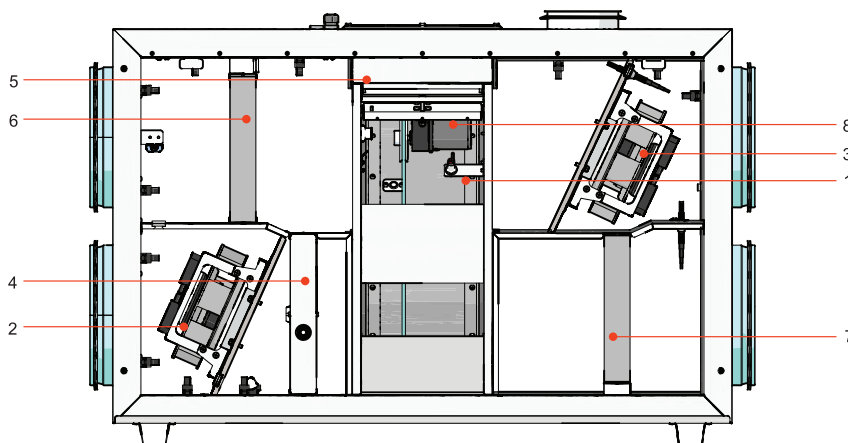

Figure 4.6.1. RIRS HE EKO 3.0 construction (left side)

1 - rotor heat exchanger; 2 - Supply fan; 3 - Exhaust fan; 4 - Electrical heater; 5 - Control board; 6 - Extract air filters (panel); 7 - Supply air filter (panel); 8 -rotor motor.

5. INSTALATION

5.1. RECEPTION OF GOODS

Each device is carefully checked before transportation. When receiving the goods, checking the devices for any damage made during transportation is recommended. If any damage to the unit is observed, immediately contact the representatives of a transport company. Please inform the representative of the manufacturer, if any deviation of the device is noticed.

5.2. TRANSPORTATION AND STORAGE

- All units are factory-packaged to withstand normal conditions of transportation.
- When unpacking, check the unit for any damage made during transportation. Installing of damaged units is not allowed!
- The packaging is used for protection purpose only!
- When unloading and storing the units, use suitable lifting equipment to avoid damage and injuries. Do not lift units by holding on power supply cables, connection boxes, air extract or exhaust flanges. Avoid hits and shock overloads. Before installation, the units must be stored in a dry room with the relative air humidity not exceeding 70% (at +20°C) and with an average ambient temperature ranging between +5 °C and +30 °C. The storage place must be protected against dirt and water.
- The units must be transported to the storage place or installation site using forklifts.
- The recommended storage period should not be longer than one year. In case of storing the units for a period longer than one year, checking if the fan bearings and motor rotate without difficulty (turning the impeller by hand) and if the electric circuit insulation is not damaged or the moisture has not accumulated must be performed before the installation of the unit.

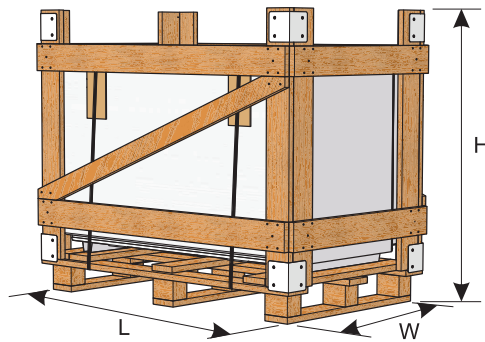

	H	W	L	Max. number of transported packages
	[mm]	[mm]	[mm]	[pcs.]
RIRS EKO 3.0				
400 HEL	950	770	1080	1
400 HER	950	770	1080	1
400 HWL	950	770	1080	1
400 HWR	950	770	1080	1
700 HEL	1055	785	1270	1
700 HER	1055	785	1270	1
700 HWL	1055	785	1270	1
700 HWR	1055	785	1270	1

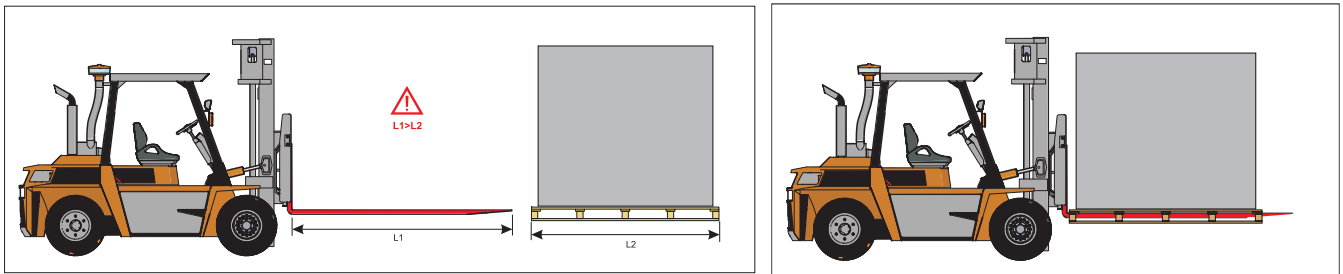

Figure 5.2.1. Lifting by forklift.



In order to prevent damage to the casing, only a product placed on a pallet should be lifted.

5.3. UNPACKING



Accessories may be packed together with the product. Prior to transporting the unit, the accessories should be unpacked first.

- Remove the film from the unit.
- Remove the bracing packaging tape that keeps the protective profiles in place.
- Remove the protective profiles.
- After unpacking the unit, examine it to make sure that no damage was made during transportation. Installing of damaged units is not allowed!
- Before commencing the installation of the unit, please check if all ordered equipment have been delivered. Any variation from the ordered equipment list must be reported to the product supplier.

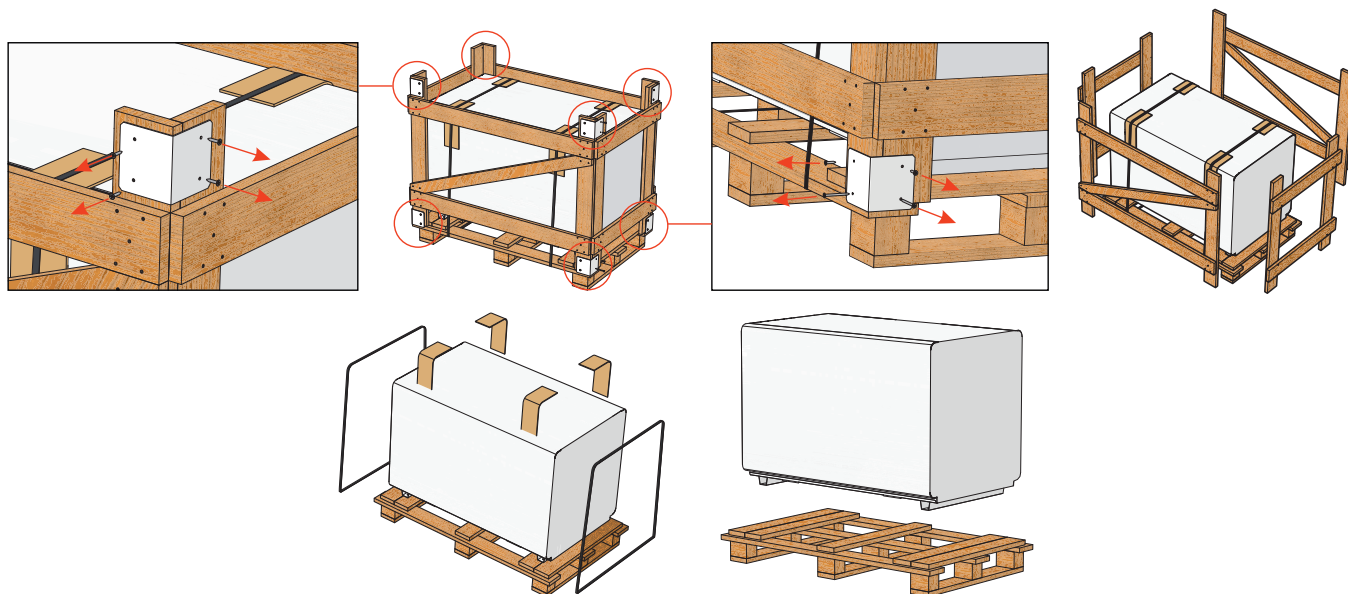

5.4. PIPING AND INSTRUMENTATION DIAGRAM

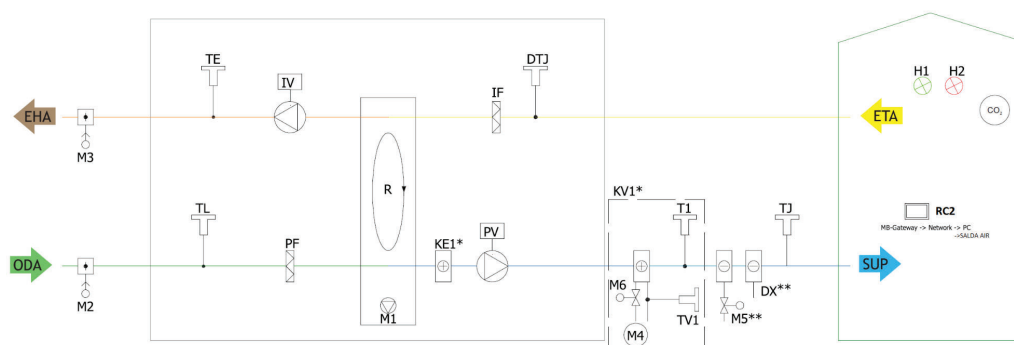

* KE1 - only in electrical version; * KV1 - used in water version; ** Possible to control.

THE LIST OF COMPONENTS

PV	Supply air fan	IF	Extract air filter
PF	Supply air filter	IV	Exhaust fan
TE	Exhaust air temperature sensor	TJ	Supply air temperature sensor
DTJ	Extract air temperature and humidity sensor	CO2	CO2 sensor
PC	Computer	KE1	Electric heater*
M2	Outdoor air damper actuator	M3	Exhaust air damper actuator
TL	Outdoor air temperature sensor		Ventilated premises
NET	Network	MB-Gateway	Network module
R	Rotor heat exchanger	DX	DX cooler
KV1	Water heater*	T1	Water heater thermostat*
M4	Water heater circulation pump*	M5	Water cooler valve motor
RC2	Stouch, Flex or ST-SA-Control remote control panel	M6	Water heater valve motor*
TV1	Water heater temperature sensor *	M1	Rotor motor

* Component/possibility to connect it depends on model.

POSSIBLE PCB INPUTS/OUTPUTS

FA	Fire alarm	H1	Working indication output
	Fans speed switch (BOOST)	H2	Alarm indication output
	System mode switch (START/STOP)		

5.5. MOUNTING

- Installation should be carried out by qualified and trained staff only.
- When connecting air ducts, consider the labels on the casing of the unit.
- Before connecting to the air duct system, the connection openings of ventilation unit should be closed.
- When connecting the ducts, the air-flow direction indicated on the device housing should be observed.
- Do not connect the bends close to connection flanges of the unit. The minimum distance of the straight air duct between the unit and the first branch of the air duct in the supply air duct must be 1xD, in air exhaust duct 3xD, where D is the diameter of the air duct.
- It is recommended to use the brackets (accessories). This will reduce the vibration transmitted by the unit to the air duct system and environment.
- Sufficient space must be provided for opening of the manhole and filter covers.
- If the ventilation unit is wall-mounted wall, it may transmit noise vibrations to the premises. Though the level of noise generated by the fans is admissible, mounting the unit at the distance of 400 mm from the nearest wall is recommended. Where this is not possible, mounting of the unit on the wall of the room where the level of noise is not significant is recommended.
- Ducts are connected to the unit in such way that they could be easily disassembled and the heater could be removed from the unit when carrying out maintenance, servicing and/or repairs



The protective film is used to protect the unit during transportation. It is recommended to remove the film; otherwise, oxidation signs may occur.

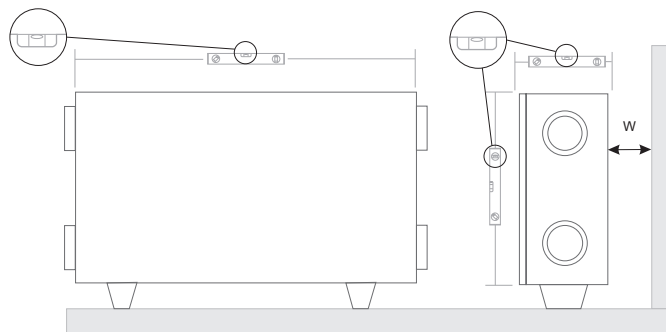

Horizontal floor-mounting positions on floor (W=400 mm)

5.5.1. UNIT PLACING AND MOUNTING POSITIONING REQUIREMENTS

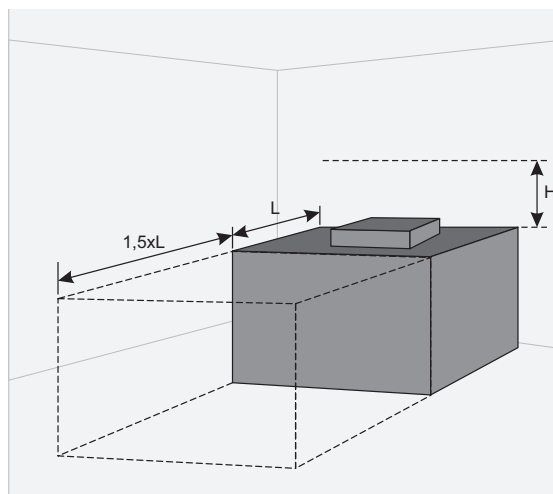

Min. distance to open the door - 1,5xL; Min. distance to open the control box door - H > 400 mm.

5.5.2. FLOOR MOUNTING

- The installation should be performed having positioned the units in horizontal direction only.
- Install the supporting legs.
- The units are assembled from separate sections.
- They must be adjusted without a gradient.
- Leave space in front (2xL) so that it would be sufficient to open the doors and to remove or install a required component.

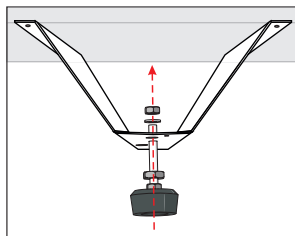

Figure 5.5.2.1. Floor mounting

5.6. CONNECTION OF THE AIR DUCT

- The connected air ducts must not be bent and have separate fixing.
- Make sure that the fans can not be accessed through air duct heads. Otherwise, protective grid should be installed. You may choose the grid from the range of products provided in our website.
- Do not reduce the diameter of the piping near air inlet or exhaust ducts. If you want to reduce the airflow speed in the system, drop of pressure and noise level, you can increase the diameter.
- In order to reduce the level of the noise in the air supply system, install dampers (see the chapter on air supply system installation).
- In order to reduce air loss in the system, the air ducts and profile components should be of class C and higher. The catalog on the above-mentioned items can be found in our website.
- External air and exhaust system piping should be isolated in order to prevent heat loss and condensation.
- Maintaining the distance of up to 8 meters between air intake and air exhaust ducts is recommended. Air supplying system should be installed away from potential air pollution sources.
- When installing air ducts next to the ventilation equipment, brackets must be used. They suppress vibration and assure secure installation of the various system parts. The necessary brackets can be found in our catalog or website.
- Air ducts are often mistakenly connected in inappropriate location. The ventilation units bear the labels indicating the correct air duct connection layout. Before starting up the system, carefully check if all related works have been performed properly.



For flange diameters see chapter " DIMENSIONS AND WEIGHT".

5.7. CONNECTION OF THE UNIT TO ELECTRIC NETWORK

- Supply voltage to the unit must be connected by a qualified specialist following the manufacturer's instructions and applicable safety guidelines.
- The unit's power network voltage must correspond to electro technical specifications of the unit indicated in the technical decal.
- The unit's voltage, power and other technical specifications are provided in the unit's technical decal (on the unit casing). The unit must be connected to the voltage plug socket of the grounded power network in accordance with the applicable requirements.
- The unit must be earthed according to electrical equipment installation regulation.
- Using extension wires (cables) and power network plug socket distribution devices is not allowed.
- Prior to carrying out any ventilation unit installation and connection works (before the unit is commissioned), the unit must be disconnected from the power network.
- After installation of the ventilation unit, the power network plug socket must be accessible at any time. If the unit is equipped with circuit breaker, disconnection from the power network is performed through the two-pole or four-pole circuit breaker (by disconnecting phase poles and neutral).
- Before it is connected to the power network, the unit must be carefully checked for any damage (execution, control, and measurement nodes) made during transportation.
- The power cable can be replaced only by a qualified technician, having evaluated the rated power and current.



The manufacturer does not assume any liability for personal injuries and property damage due to nonconformance with the provided instructions.

5.8. START-UP RECOMMENDATIONS

5.8.1. SYSTEM PROTECTION

The control board of the unit is equipped with the following integrated devices for the protection against short circuit:

RIRS EKO 3.0	400 HE	400 HW	700 HE	700 HW
F1	10 A	5 A	15 A	10 A
F2	6,3 A	1 A	10 A	1 A

It is recommended to use the unit with external electrical protection device.

RIRS EKO 3.0	400 HE	400 HW	700 HE	700 HW
Mains Fuse	10 A	6 A	16 A	6A



To ensure safe maintenance of the unit, it is necessary to turn off main switch and/or external protection device.

5.8.2. PRE-STARTUP RECOMENDATIONS OF THE UNIT (IN THE PRESENCE OF THE ENDUSER)

Prior to start-up, the system must be carefully cleaned. Check for the following:

- operation systems and unit elements as well as automation and automation devices were not damaged during installation,
- all electrical devices are connected to power supply and fit for service,
- all necessary automation elements are installed and connected to power supply and terminal blocks,
- cable connection to terminal blocks comply with the existing wiring diagrams,
- all electrical equipment protection components are properly connected (if they are additionally used),
- cables and wires correspond to all applicable safety and functional requirements, diameters, etc.,
- earthing and protection systems are properly installed,
- condition of all seals and sealing surfaces is proper.

6. MAINTENANCE

6.1. SAFETY INSTRUCTION



Unplug the unit from the mains before opening the door (disconnect the power plug from the outlet or in case a two-pole automatic circuit breaker installed, disconnect it as well. Make sure that it cannot be turned on by third parties) and wait until the fans completely stop (for about 2 min.).

6.2. GENERAL RECOMMENDATIONS FOR VENTILATION SYSTEM MAINTENANCE

In order to ensure proper functioning of the system, maintenance requirements and its periods should be observed. Otherwise, the warranty shall be void. Some recommendations are provided in the table below, but they are just advisory, as the need for system maintenance depends on the location of the unit installation, the pollution of atmosphere, population, working hours, etc.

COMPONENT	DURING START-UP	AT LEAST EVERY 6 MONTHS
Filters	Check the cleanliness of the filters	Replace filters every 3 to 4 months or according to the control device indications. Check cleanliness. Clean, if necessary Make sure that the impellers are not unbalanced.
Fans	Check the connections and the direction of rotation	Make sure that the impellers do not cause noise when rotated by hand. Make sure that the fastening screws are not loose and free of mechanical damage. Check electrical connections and make sure that these are secured properly and are free of signs of corrosion.
Rotor heat exchanger	Check the cleanliness of the heat exchanger	Check cleanliness and clean, if necessary Check the tension of a belt
Control panel	Check the connections	Check the connections
Electric heater	Check the connections	Clean off dust, and check the electrical components and connections of the heater
Pressure sensor	Check electrical connections	Check the operation
Temperature sensor	Check electrical connections	Check the operation
Air intake and discharge system	Check the connections	Clean
Air duct system	Check the tightness	Clean
Dampers, diffusers, grid	Check the tightness of connections	Clean
Switching unit (contactor)		Every 3 to 4 months, visually assess the functioning of the switching unit (contactor), i.e. make sure that its casing has no signs of melting or is not thermally damaged in any way and does not produce any unusual sounds. All the contactors in the product or in its accessories must be checked.

6.3. COVER OPENING

Before opening the covers, first, unplug the unit from the mains, then wait for 2 minutes (until the fans completely stop).

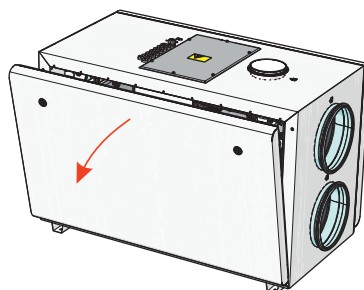

6.4. FILTERS MAINTENANCE

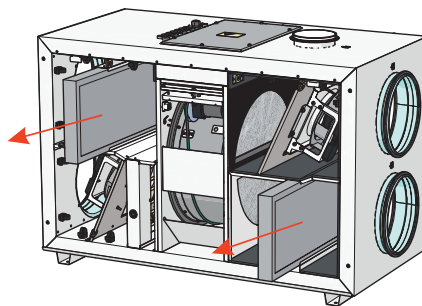

In order to remove the filters, open unit door and take off the filters.

Dirt increases air resistance in the filter, therefore, lower amount of air is supplied into the premises. Arrows on the filters must comply with airflow direction.



After changing the filters, please reset the filter timer. The instruction on resetting can be found in the control panel operation manual or on our website www.salda.it
Operation of the unit without filters is not allowed.



Change the filters every 3-4 months or according to the notification on the control device.

6.5. ROTOR MAINTENANCE MAINTENANCE

- Maintenance of rotor heat exchanger must be performed on annual basis, once per year.
- Ensure the gaps of heat exchanger are clean, the brushes are not worn, the belt drive is not worn, and the clamping nodes of the rotor heat exchanger are tight.
- Rotor heat exchanger can be easily removed from the unit. Disconnect the power cord of the motor of heat exchanger, release and raise the clamp of the rotor heat exchanger section, and then remove the heat exchanger.
- Heat exchanger must be cleaned using the solution of warm water and non-corrosive toward aluminium alkaline agent or an air stream. Applying direct stream of liquid is not recommended, because this can cause damage to the device.
- While cleaning, make sure that no moisture and liquid will enter into the motor of the heat exchanger.
- Having reinstalled the heat exchanger, fasten its section with the clamp. Connect the heat exchanger motor.

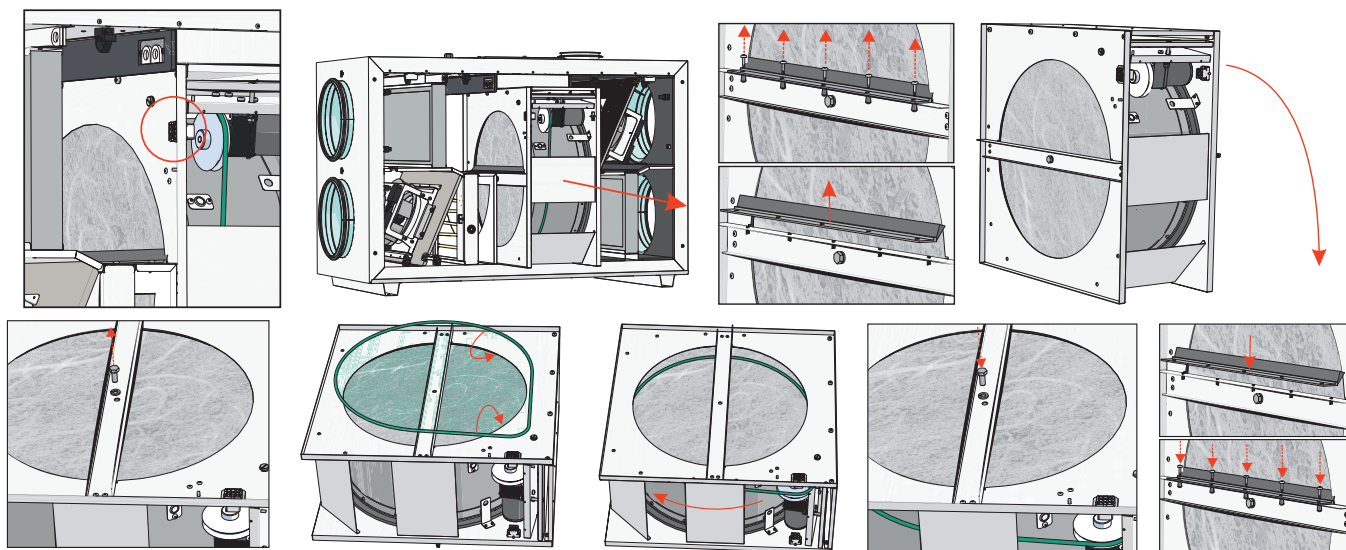

CAUTION: heat exchanger cannot be used when the filters are removed!

6.6. FANS MAINTENANCE

- Fan maintenance should be performed by experienced and trained staff only.
- The fan should be inspected and cleaned at least once per year.
- Prior to commencing any maintenance or repairs, make sure the fan is disconnected from the power source.
- Proceed to maintenance and repair after any fan rotation is stopped.
- Observe staff safety regulations during maintenance and repairs.
- The fans features a heavy-duty ball bearing design. The motor is completely sealed and free of maintenance.
- Detach the fan from the unit.
- The impeller should be particularly checked for built-up material or debris that may cause an imbalance. Excessive imbalance may lead to accelerated wear on motor bearings and vibration.
- Clean the impeller and inside housing with a mild detergent, water and damp, soft cloth.

- Do not use high-pressure cleaner, abrasives, sharp tools or caustic solvents that may scratch or damage the housing and impeller.
- Do not plunge the motor into any fluid while cleaning the impeller. Make sure the impeller's balance weights are not moved.
- Make sure the impeller is free of any obstacles.
- Install the fan back into the unit. Connect fan power and control signals.
- In case the fan after maintenance does not automatically start up or stop, contact the manufacturer. Malfunction of the fan can be identified by the pressure in the system (when pressure switches are connected). In case of any fault in the fan motor, a notice will appear on the control panel.

⚠ Prior to commencing any maintenance or repairs , make sure the ventilation units is disconnected from the power source.

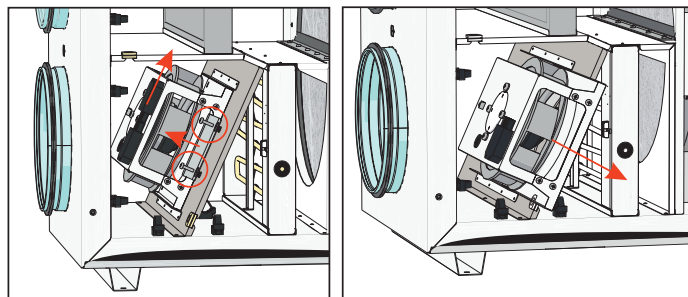

6.7. HEATER MAINTENANCE

- In case manual protection is activated, check for a fault before pressing the RESET button. If the fault is identified after it has been rectified, press the RESET button using a screwdriver or a similar object.
- Electrical heater does not require additional servicing. The filters must be replaced as described above.
- Heaters are equipped with 2 thermal protection devices: an automatic self-resetting protection device that is activated at +50 °C, and a manually restored protection device that is activated at +100 °C.
- After an activation of the manually restored protection device, make sure the unit is disconnected from the power supply. Wait until all heating elements cool down and the fans completely stop. Having identified and rectified the failure, to start the unit, press the RESET button. The failure can be identified by a qualified technician only.
- If necessary, electric heater can be removed. Disconnect the electrical connector from the heater and remove the heater.

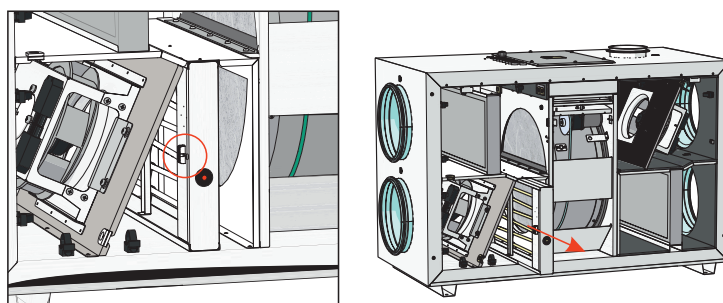

6.8. CONTROL BOARD MAINTENANCE

- Disconnect product unit from electric power source.
- Unscrew the bolts on the control box.
- Remove the control box cover.
- Disconnect all cables, wires, and connectors from the control board and unscrew the control board mounting bolts.
- Remove control board.
- To reassemble, follow all maintenance steps in reverse order. When re-connecting cables, wires, and connectors, make sure to match each wire and connector to corresponding connection terminal and connector.

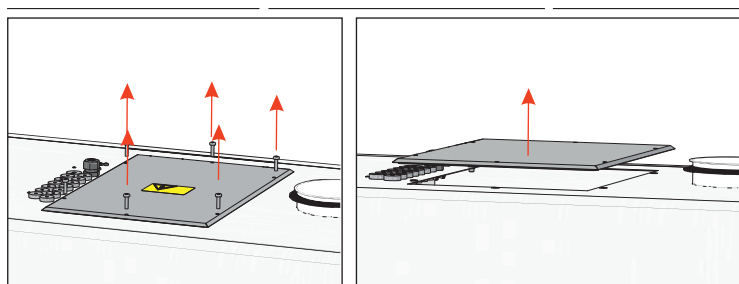

7. CONTROL

7.1. DEVICE CONTROL

Ventilation unit equipped with PRV control board can be controlled with remote controller, WEB interface or mobile app via MB-GATEWAY and BMS (building management system). More information provided in the table below.

With MB-GATEWAY	Remote control panels	BMS direct connection	Wireless communication
Web interface SALDA AIR mobile application BMS over Modbus TCP/IP BMS over BACnet TCP/IP	Stouch ST-SA-Control FLEX	Modbus RTU (RS485)	MB-GATEWAY + WIFI router

7.2. DEVICE FUNCTIONS







PRV control board operation functions and control of the device depends on the following:



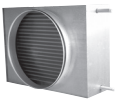











1. Selected control interface (remote control panel, MB-GATEWAY, etc.). The selected interface affects access to the information and settings, however, it does not affect the logic of control. Full access to the information and settings is available on FLEX, ST-SA-Control, MB-GATEWAY WEB application and SALDA AIR mobile application.
2. Unit configuration (internal/external components, sensors and control board settings).



Refer to the instruction manual of the existing control device for unit control instructions.

8. ACCESSORIES

RIS EKO 3.0		400 HE	400 HW	700 HE	700 HW	
Outlet covers		ABV 250	-	-	ACC000056	ACC000056
		WSG 200	FIT000404	FIT000404	-	-
		ALU 200	FIT000128	FIT000128	-	-
Valves		VVP45.10-0.63	ACC000140	ACC000140	ACC000140	ACC000140
		VXP45.10-0.63	ACC000143	ACC000143	ACC000143	ACC000143
Heater/cooler insulated (module)		CB 250 C2+DE	-	-	ACC000151	ACC000151
		CB 250 C4+DE	-	-	ACC000152	ACC000152
		CB 250 F2+DE	-	-	ACC000153	ACC000153
		CB 250 F4+DE	-	-	ACC000154	ACC000154
		CB 250 H1	-	-	-	ACC000155
		CB 250 H1+C2+DE	-	-	-	ACC000156
		CB 250 H1+C4+DE	-	-	-	ACC000157
		CB 250 H1+F2+DE	-	-	-	ACC000158
		CB 250 H1+F4+DE	-	-	-	ACC000159
		CB 250 H2	-	-	-	ACC000160
		CB 250 H2+C2+DE	-	-	-	ACC000161
		CB 250 H2+C4+DE	-	-	-	ACC000162
		CB 250 H2+F2+DE	-	-	-	ACC000163
CB 250 H2+F4+DE	-	-	-	ACC000164		
Heaters/coolers (on duct)		AVA 200	ACC000192	ACC000192	-	-
		AVA 250	-	-	ACC000193	ACC000193
		AVS 200	-	ACC000199	-	-
		AVS 250	-	-	-	ACC000200
External sensors		Sensor CO ₂ duct S-KCO2	ACC000277	ACC000277	ACC000277	ACC000277
		Sensor CO ₂ room S-RCO2-F2	ACC000278	ACC000278	ACC000278	ACC000278
		Pressure transmitter S-1141	ACC004375	ACC004375	ACC004375	ACC004375
Dampers		SKG-A 200	FIT000204	FIT000204	-	-
		SKG-A 250	-	-	FIT000205	FIT000205

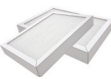
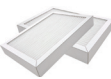
		Network module MB-Gateway	ACC000269	ACC000269	ACC000269	ACC000269
		Remote control panel FLEX	ACC000270	ACC000270	ACC000270	ACC000270
		Remote control panel ST-SA-Control	ACC000271	ACC000271	ACC000271	ACC000271
Control		Remote control panel Stouch	ACC000272	ACC000272	ACC000272	ACC000272
		Switch 774451 + 774411	ACC004460	ACC004460	ACC004460	ACC004460
		Router TP-Link TL-WR802N	ACC000273	ACC000273	ACC000273	ACC000273
		Actuator for damper CM230-1-F-L (2 Nm, on-off)	ACC000305	ACC000305	ACC000305	ACC000305
Actuators		Actuator for damper TF230 (2 Nm, spring, on-off)	-	ACC000316	-	ACC000316
		Actuator for water valve SSB61 200 Nm	-	ACC000317	-	ACC000317
		Actuator for water valve SSB81 200 Nm	ACC000318	ACC000318	ACC000318	ACC000318
		MUTE 200X600	FIT000291	FIT000291	-	-
Silencers		MUTE 200X900	FIT000292	FIT000292	-	-
		MUTE 250X600	-	-	FIT000293	FIT000293
		MUTE 250X900	-	-	FIT000294	FIT000294
		Filter set RIRS 400 V/H EKO 3.0 (ePM10-50+ePM1-70-2pcs.)	ACC005258	ACC005258	-	-
Filter sets		Filter set RIS 700 H EKO 3.0 (ePM10-65-2pcs.)	-	-	ACC004878	ACC004878

8.1. CONNECTION OF ACCESSORIES

8.1.1. FIRE PROTECTION SIGNAL INPUT (FIRE PROTECTION INPUT (NC))

Fire protection signal input must be normally closed, until the fire protection system is not connected a jumper is installed in the factory.

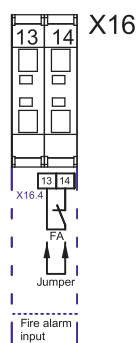

8.1.2. EXTERNAL CO2 /PRESSURE SENSORS

RIRS H EKO 3.0 units have two connections for external CO2/PRESSURE (input 0-10 VDC) sensors

Sensors connection:

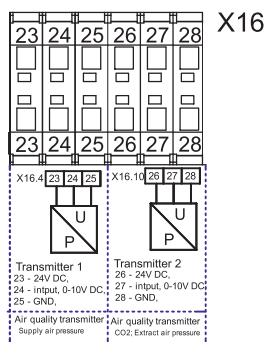

These sensors are intended for the following 3 functions: supply air pressure, extract air pressure and extract CO2 detection. Supply air pressure is measured inside the supply air duct referenced to the unit's surrounding area. Extract air pressure is measured inside the extract air duct referenced to the unit's surrounding area. The CO2 transmitter is installed in the extract air duct or room.

8.1.3. ROOM CO2 TRANSMITTER INSTALLATION RECOMMENDATION

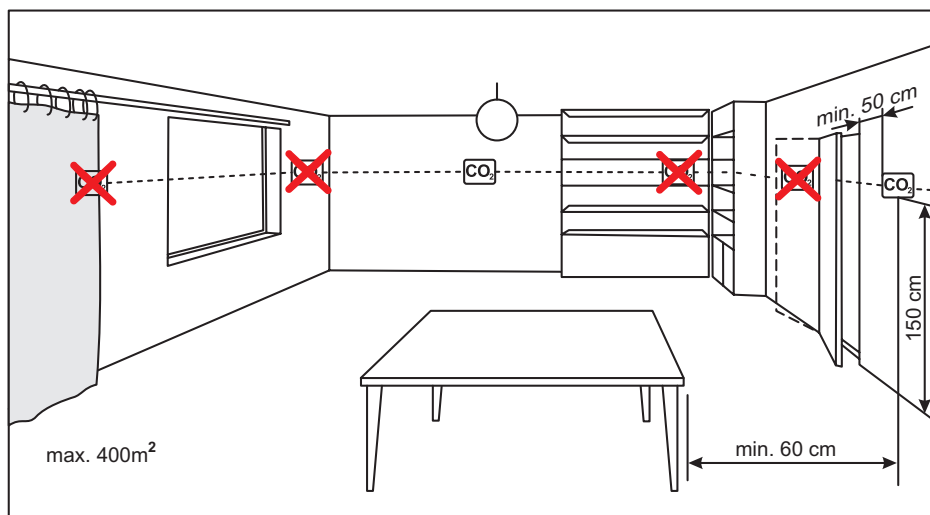

If the duct CO2 transmitter is used, it must be installed in the extract air duct. To install duct transmitters, hole drilling tools are required .

8.1.4. CO2 CONCENTRATION ACCORDING TO PETTENKOFER LIMIT

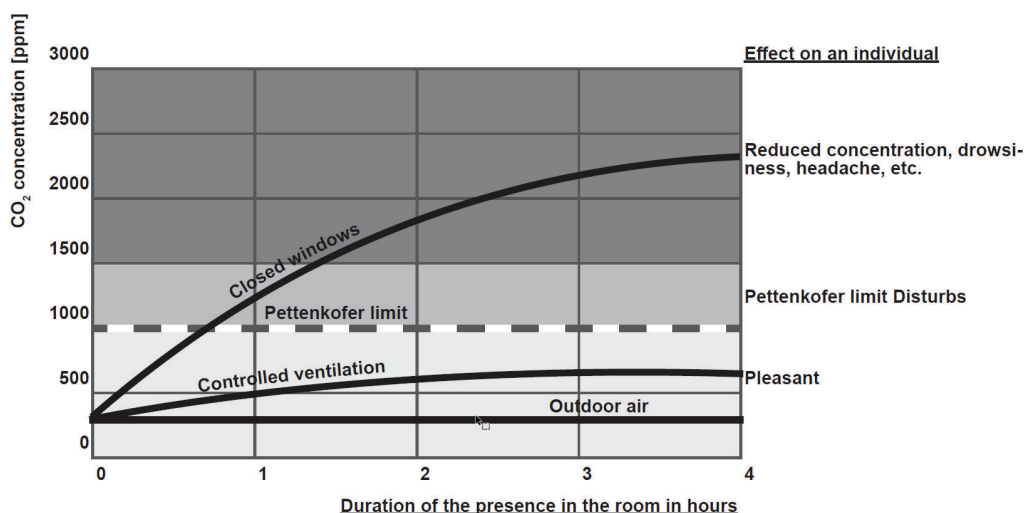

8.1.5. CONNECTION OF SUPPLY AND EXTRACT AIR DAMPERS

Product RIRS H EKO 3.0 can be equipped with supply air and extract air dampers. Dampers are controlled by Open/Close or Spring-return actuators.

Wiring diagram for RIRS 400-700 HE EKO 3.0

M2, M3 – Open/Close damper actuators. Upon activation of outputs X16:17, X16:20 the dampers shall open, Upon activation of outputs X16:16, X16:19 the dampers shall close.

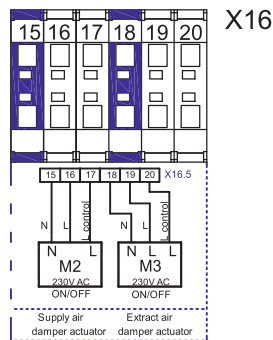

Wiring diagram for RIRS 400-700 HW EKO 3.0

M2 – Spring-return damper actuator. M3 – Open/Close damper actuator. Upon activation of outputs X16:17, X16:20, the dampers open, Upon activation of output X16:19, the extract air damper close. The supply air damper is controlled by spring-return actuator so that when output X16:16 is deactivated, the supply air damper closes.

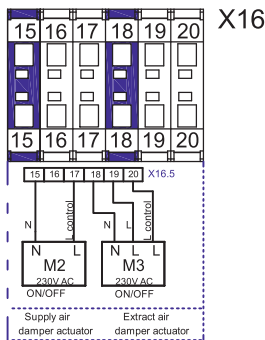

8.1.6. CONNECTION OF REMOTE CONTROL PANEL OR MODBUS

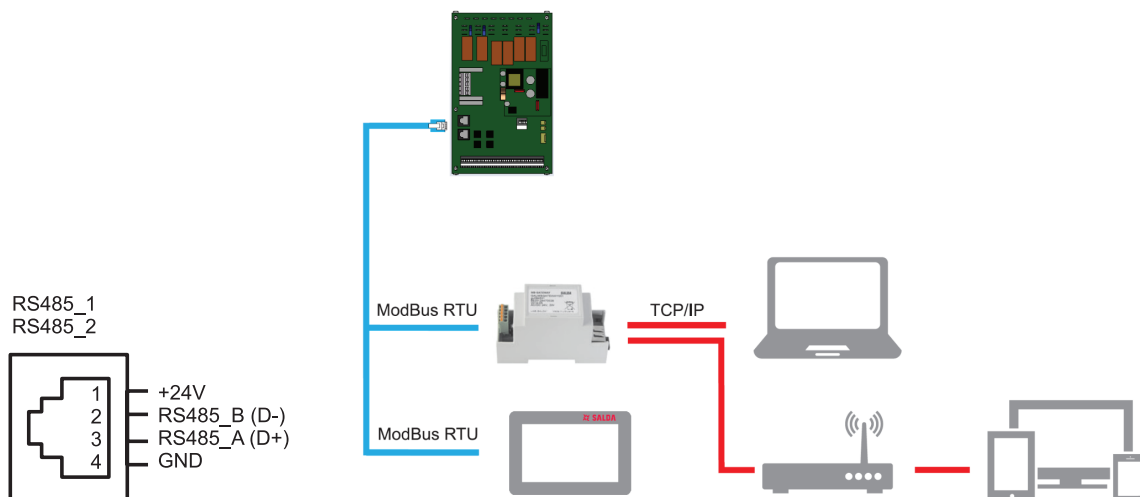

8.1.7. WATER HEATER CIRCULATION PUMP AND VALVE ACTUATOR

Water heater circulation pump and valve actuator can only be connected to the units that are designed to operate with water heater (RIRS HW EKO 3.0 units).

Wiring diagram

Valve actuator is controlled by 0-10 VDC signal. Circulation pump is controlled by On/Off signal.

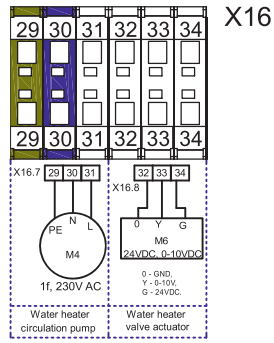

8.1.8. RECOMMENDED SCHEME FOR CONNECTION OF INTERNAL AND EXTERNAL COMPONENTS

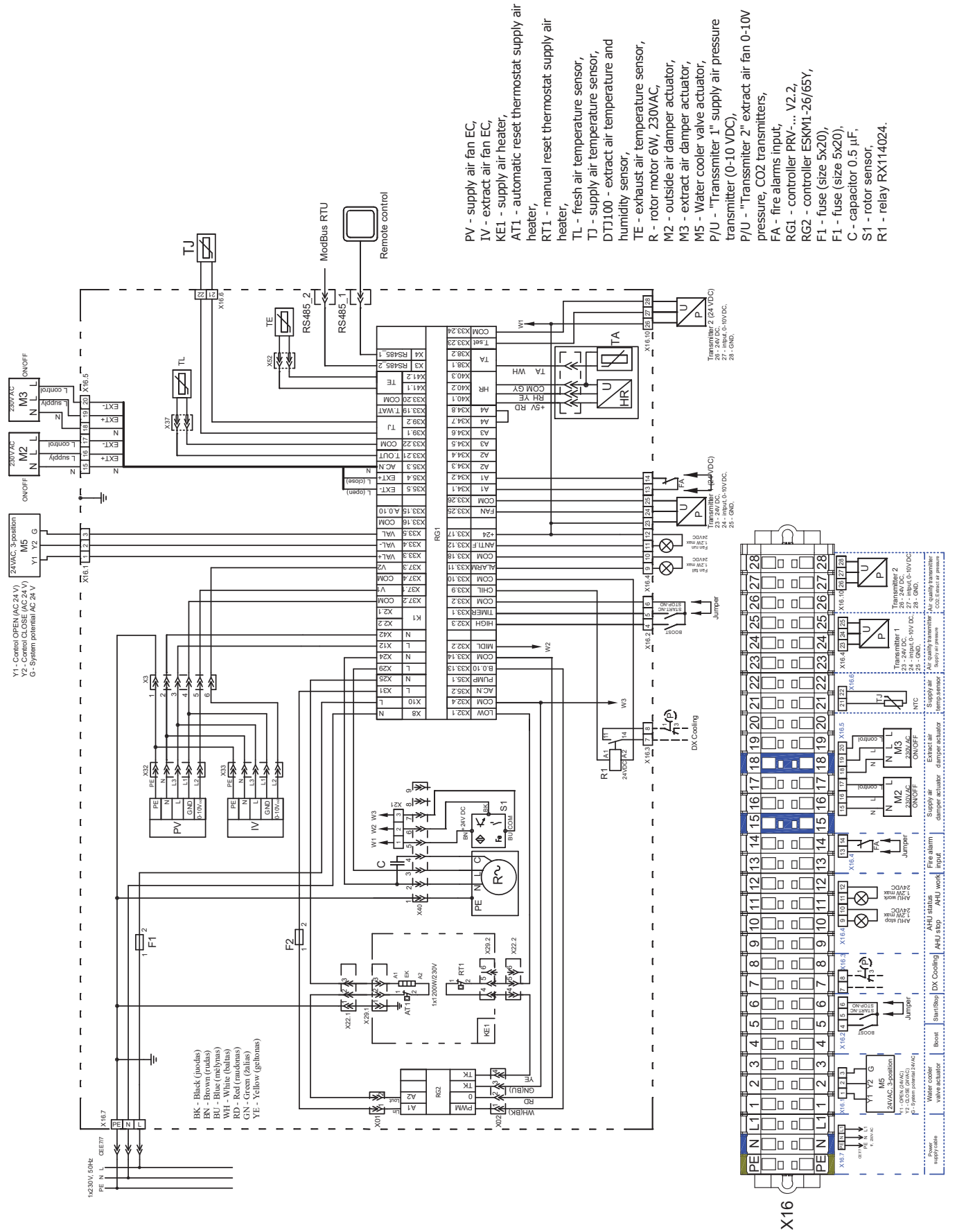

Figure 8.1.8.1. RIRS 400/700 HE EKO 3.0

PV - supply air fan EC,
 IV - extract air fan EC,
 TL - fresh air temperature sensor,
 TJ - supply air temperature sensor,
 DTJ100 - extract air temperature and humidity sensor,
 TE - exhaust air temperature sensor,
 TI - antifrost thermostat,
 TV - antifrost sensor,
 R - rotor motor 6W, 230VAC,
 M2 - outside air damper actuator,
 M3 - extract air damper actuator,
 M4 - water heater circulatory pump,
 M5 - water cooler valve actuator,
 M6 - water heater valve actuator.
 P/U - "Transmitter 1" supply air pressure transmitter (0-10 VDC),
 P/U - "Transmitter 2" extract air fan 0-10V pressure, CO2 transmitters,
 FA - fire alarms input,
 RG1 - controller PRV... V2.2,
 F1 - fuse 10A (size 5x20),
 F2 - fuse 1A (size 5x20),
 C - capacitor 0.5 mF,
 S1 - relay.

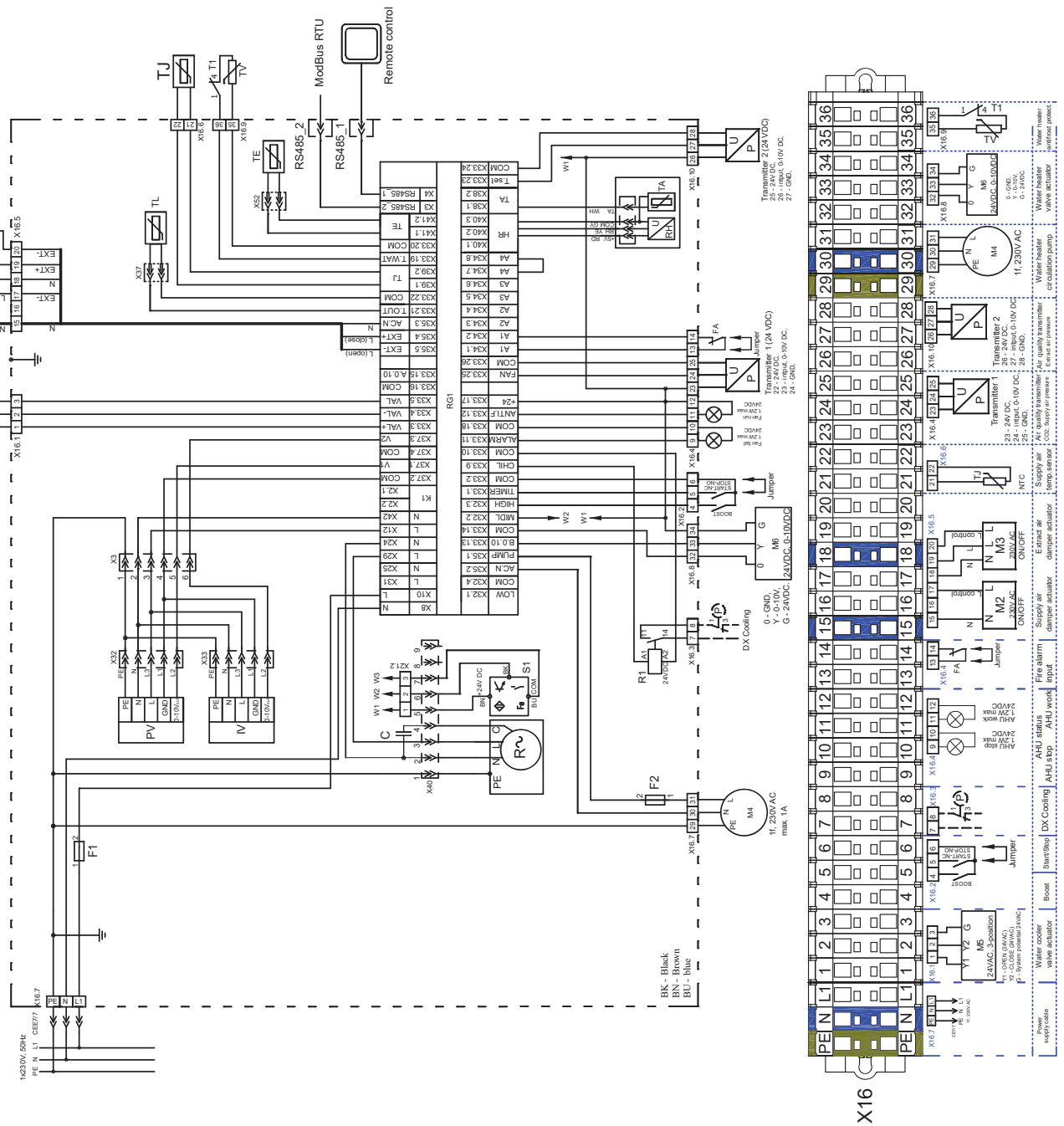

Figure 8.1.8.2. RIRS 400/700 HW EKO 3.0

9. POSSIBLE FAULTS AND TROUBLESHOOTING

FAILURE	CAUSE	EXPLANATION / CORRECTIVE ACTIONS
Unit is not operating	No supply voltage	Check whether the device is connected to the power network
	Protection device is off or a current leakage relay is active (if installed by the installer)	Switch on only if the unit condition has been evaluated by a qualified electrician. If the system failed, the failure MUST BE rectified prior to switching it on.
Air supply heater or pre-heater is not operating or malfunctioning (if installed)	Too low air flow in air ducts activates automatic protection	Check if air filters are not clogged Check if fans are rotating
	Manual protection is activated	Possible heater or unit failure. MUST contact the servicing staff for failure detection and its elimination.
Too low air flow at rated fan speed	Clogged supply and/or extract air filter(s)	Filter replacement needed
Filters are clogged and no message is shown on the remote control	Wrong time in filter timers or their switch is broken, or its pressure is set improperly.	Shorten filter timer time to the message of clogged filters or replace the pressure switch of the filters, or set their proper pressure.
Rotor is not rotating	Rotor belt is broken	Inspect the rotor belt. If it is broken then it should be changed or re-welded.
Rotor belt failure	Rotor belt is slipping	If belt is not broken, check its tightness and adjust, if necessary.

10.ECODESIGN DATA TABLE

MODEL			RIRS 400 HE/HW EKO 3.0			
Climate zone	Control typology	Control factor	Specific energy consumption (SEC)	SEC Class	AEC	AHS
			[kWh/m ² /a]		[kWh/a]	[kWh/a]
Average	Central demand control (standard with 1 sensor)	0,85	-35,4	A	272	4224
	Local demand control (opt. with 2 sensors)	0,65	-39,9	A	159	4383
Cold	Central demand control (standard with 1 sensor)	0,85	-75,8	A+	272	8262
	Local demand control (opt. with 2 sensors)	0,65	-81,8	A+	159	8574
Warm	Central demand control (standard with 1 sensor)	0,85	-12,3	E	272	1910
	Local demand control (opt. with 2 sensors)	0,65	-15,8	E	159	1982
Declared typology			Bidirectional			
Type of drive installed (fan)			Variable			
Type of heat recovery system			regenerative			
Thermal efficiency of heat recovery		[%]	75			
Maximum flow rate		[m ³ /h]	400			
Electric power input of the fan drive at maximum flow rate		[W]	167			
Sound power level (Lwa)		[dB(A)]	46			
Reference flow		[m ³ /s]	0,08			
Reference pressure difference		[Pa]	50			
SPI		[W/(m ³ /h)]	0,3			
Declared maximum internal leakage rates		[%]	5			
Declared maximum external leakage rates		[%]	3			
Position and description of visual filter warning for RVU's			Timer			
ErP Compliance			2018			
Internet address for disassembly instructions			www.salda.it			

MODEL			RIRS 700 HE/HW EKO 3.0			
Climate zone	Control typology	Control factor	Specific energy consumption (SEC)	SEC Class	AEC	AHS
			[kWh/m ² /a]		[kWh/a]	[kWh/a]
Average	Central demand control (standard with 1 sensor)	0,85	-34,5	A	290	4169
	Local demand control (opt. with 2 sensors)	0,65	-39,2	A	169	4341
Cold	Central demand control (standard with 1 sensor)	0,85	-74,3	A+	290	8156
	Local demand control (opt. with 2 sensors)	0,65	-80,7	A+	169	8493
Warm	Central demand control (standard with 1 sensor)	0,85	-11,6	E	290	1885
	Local demand control (opt. with 2 sensors)	0,65	-15,4	E	163	1963
Declared typology			Bidirectional			
Type of drive installed (fan)			Variable			
Type of heat recovery system			regenerative			
Thermal efficiency of heat recovery		[%]	73			
Maximum flow rate		[m ³ /h]	735			
Electric power input of the fan drive at maximum flow rate		[W]	343			
Sound power level (Lwa)		[dB(A)]	48			
Reference flow		[m ³ /s]	0,14			
Reference pressure difference		[Pa]	50			
SPI		[W/(m ³ /h)]	0,32			
Declared maximum internal leakage rates		[%]	5			
Declared maximum external leakage rates		[%]	3			
Position and description of visual filter warning for RVU's			Timer			
ErP Compliance			2018			
Internet address for disassembly instructions			www.salda.it			

11. DECLARATION OF CONFIRMITY

Manufacturer

SALDA, UAB
Ragainės g. 100
LT-78109 Šiauliai, Lithuania
Tel.: +370 41 540415
www.salda.lt

Hereby confirms that the following products - Air handling units:

RIRS * EKO 3.0

(where by „*“ indicates possible unit installation type and modification)

Provided it was delivered and installed in the facility in accordance with the included installation instructions, comply with all applicable requirements in the following directives:

Machinery Directive 2006/42/EC
EMC Directive 2014/30/EU
Low Voltage Directive 2014/35/EU
Ecodesign Directive 2009/125/EC
RoHS 2 Directive 2011/65/EU

The following regulations are applied in applicable parts:

Ecodesign requirements for ventilation units Nr. 1253/2014
Energy labeling of residential units Nr. 1254/2014

The following harmonized standards are applied in applicable parts:

EN 13141-7:2010 - Ventilation for buildings - Performance testing of components/products for residential ventilation - Part 7: Performance testing of a mechanical supply and exhaust ventilation units (including heat recovery) for mechanical ventilation systems intended for single family dwellings.
EN ISO 12100:2012 - Safety of machinery - General principles for design - Risk assessment and risk reduction.
EN 60204-1:2018 - Safety of machinery - Electrical equipment of machines - Part 1: General requirements.
EN 60335-1:2012 - Household and similar electrical appliances. Safety. Part 1: General requirements.
EN 60529:1999/A2:2014/AC:2019 - Degrees of protection provided by enclosures (IP code).
EN IEC 61000-6-1:2019-03 - Electromagnetic compatibility (EMC) -- Part 6-1: Generic standards - Immunity for residential, commercial and light-industrial environments.
LST EN 61000-6-3:2008 - Electromagnetic compatibility (EMC) -- Part 6-3: Generic standards - Emission standard for residential, commercial and light-industrial environments.

Should any alterations be made in the products, this declaration will no longer apply.

Quality: SALDA UAB activities are in line with the international quality management system standard **ISO 9001:2015**.

Date 2020-10-23



Giedrius Taujenis
Director product development

12. WARRANTY

1. All equipment manufactured in our factory is checked in operating conditions and tested before delivery. Test protocol is supplied together with the unit. The equipment is shipped in good working condition to the end-client. The unit is warranted for the period of two years from the invoice date.
2. If equipment is found to have been damaged during transportation, a claim should be made against carrier, as we assume no responsibility for such damage.
3. This warranty does not apply:
 - 3.1. when transportation, storage, installation and maintenance instructions of the unit are violated;
 - 3.2. when the equipment is improperly maintained, mounted - inadequate maintenance;
 - 3.3. when the equipment without our knowledge and permission has been upgraded or unskilled repairs were made;
 - 3.4. when the unit was used not for its original purpose.
 - 3.5. Company SALDA UAB is not responsible for potential loss of property or personal injury in cases where AHU is manufactured without a control system and the control system will be installed by the client or third parties. The manufacturer's warranty does not cover devices that will be damaged by installing the control system.
4. This warranty does not apply at these malfunction cases:
 - 4.1. mechanical damage;
 - 4.2. damage caused by entering outside objects, materials, liquids;
 - 4.3. damage caused by natural disaster, accident (voltage change in the electricity network, lightning, etc..).
5. The company assumes no liability for its products either directly or indirectly damage, if the damage is caused by failure to comply with installation and mounting regulations, deliberate or careless users or third-party behavior.

These conditions are readily discernable when the equipment is returned to our factory for inspection.

If the direct client determines that equipment is found to be faulty, or a breakdown occurred, he should inform the manufacturer within five working days and deliver the equipment to manufacturer. Delivery costs should be covered by customer.



Manufacturer reserves the right to change this technical passport any time without prior notice, if some typographic errors or inaccurate information is found, as well as after improving the apps and/or the devices. Such changes will be included in the new issues of the technical passport. All illustrations are just for information and thus may differ from the original device.

12.1. LIMITED WARRANTY COUPON

Warranty term

24 months*

I received complete package and technical manual of the product ready for usage. I have read warranty terms and conditions and agree with them:

.....
Customer's signature

*refer to WARRANTY CONDITIONS

Dear User, we appreciate your choice and do hereby guarantee that all ventilation equipment manufactured by our Company is inspected and thoroughly tested. An operational and high-quality product is sold to the direct buyer and shipped from the territory of the factory. It is provided with a 24-month warranty since invoice issue date.

Your opinion is important to us, thus we always look forward to hearing your comments, feedback, or suggestions regarding technical and operational characteristics of the Products.

In order to avoid any misunderstandings, please read the instructions for installation and operation of the product as well as other technical documents of the product carefully. The number of the Limited Warranty Coupon and serial number of the product specified on the silver identification sticker attached to the housing must match.

The Limited Warranty Coupon shall be valid provided that the seller's stamps and records are clear. It is not allowed to change, delete, or rewrite the data specified on it in any manner – such a coupon shall be invalid.

With this Limited Warranty Coupon the manufacturer confirms one's obligations to implement the imperative requirements established by effective laws on protection of consumer rights in the event of identification of any defects of the products.

The manufacturer reserves the right to refuse provision of free warranty servicing in cases when the warranty conditions listed below are disregarded.

PRODUCT MAINTENANCE TABLE

Product name*		
SERIAL number*		
installation	interval	Date
Fan cleaning	Once per year**	_____
Heat-exchanger cleaning	Once per year**	_____

Filter replacement	Every 3-4 months**	_____

* - Look at the product label.

** - At least.

NOTE. The customer shall be required to complete the Product Maintenance Table.

MANUALS IN OTHER LANGUAGES

DE



https://select.salda.lt/file/rirs400_700hekode

DK



https://select.salda.lt/file/rirs400_700hekodk

FR



https://select.salda.lt/file/rirs400_700hekofr

LT



https://select.salda.lt/file/rirs400_700hekolt

PL



https://select.salda.lt/file/rirs400_700hekopl

RU



https://select.salda.lt/file/rirs400_700hekoru



MAN000313

