

UG8-E-230 UNIGUARD STAND-ALONE-UNIT

Optical smoke detector with service alarm for duct mounting. Free-rotation in any direction.
Electronic airflow indication.



TECHNICAL DATA

Supply voltage:	230V AC/DC $\pm 10\%$ No polarity sensitivity
Detector type:	Optical EVC-PY-DA
Max power consumption:	< 100 mA
Operating temperature:	-10°C to +55°C
Humidity:	Max. 95% RH
Duct airspeed range:	1 to 20 m/s
Approvals:	CE, EN-54-27
Relay outputs:	Potential-free
Smoke alarm relays:	1 change-over relay 250V, 8A and 1 breaking relay 250V, 8A
Service and Low-airflow alarm:	1 breaking relay 250V, 1A
System failure alarm:	1 breaking relay 250V, 1A
Smoke detector LED:	Yellow – Service alarm (contamination) Red – Smoke alarm
Circuit board LED:	Green – Normal operation Flashing yellow – System failure Yellow – Low flow
Enclosure:	PC/ABS
Venturi tube:	Aluminium
Protection class:	IP65

EXAMPLE OF ORDER

Item code	Designation
UG8-E-230	Optical duct smoke detector 230V Stand-alone

ACCESSORIES

Item code	Designation
UG-MB-8	Mounting bracket (for insulated/ round ducts)
UG-COVER-75	Protective cover (for mounting outdoors, in non-insulated attics, etc.)
ST280*	Venturi tube, aluminium (length: 280 mm)
ST580*	Venturi tube, aluminium (length: 580 mm)
ST-EXTEND	Extension of STx Venturi tube, 1.06 m

* Venturi tube sold separately.

FEATURES

- High-efficiency internal detection duct allows for the use of HyperFlow Venturi tubes
- HyperFlow Venturi tubes made of UL-certified PC/ABS
- 360° rotatable detector enclosure, patent pending
- Automatic sensitivity adjustments lead to a longer service life and fewer false alarms due to contamination
- Service alarm
- Test hole on the cover
- Easy installation
- Electronic airflow indicator

FUNCTION

The UG8 Uniguard has been developed to measure smoke in ventilation ducts and consists of a smoke detector and duct enclosure system, specially-designed for optimal airflow through the smoke detector.

The UG8 can be mounted on either side of the duct. The UG8 comes a rotating section that, together with your chosen Venturi tube, is mounted on the ventilation duct. It also has a “FLOW arrow” for easy installation in the correct direction for the airflow. The direction of the arrow should correspond with the direction of the airflow in the duct. The patent-pending detector enclosure with cable inputs and reset button can be rotated in any direction to suit the characteristics of the mounting location. Both the smoke detector chamber and connection chamber covers have snap locks for quick access.

Relays:

- Two **alarm relays** to, for example, control fire protection dampers or to start/stop the ventilation fans.
- A **service alarm relay and low-flow alarm relay**, which indicate when maintenance is needed before a false alarm occurs, as well as that the airflow in the duct is low or that the UG8 is mounted at an unsuitable place in the duct.
- A **system failure relay**, which indicates failures in the smoke detector circuit.

The detector has an intelligent monitoring circuit that constantly checks and adjusts the sensitivity for optimum functionality throughout its service life. When the detector can no longer compensate for contamination and starts to approach a false alarm, a service alarm will be indicated.

The detector is fitted with a bayonet mount, making it easy to fit and remove. If a system failure occurs in the UG8, e.g. if a detector is removed, a yellow LED on the circuit board will start to flash and the system failure relay will be disabled. In the event of a system failure, other relays will also be disabled. The UG8 can be used with Calectro’s ST280 and ST580 Venturi tubes, as well as the extension tube ST-EXTEND.

UG8-E-230 UNIGUARD STAND-ALONE-UNIT

Optical smoke detector with service alarm for duct mounting. Free-rotation in any direction. Electronic airflow indication.



BASIC PRINCIPLES OF PLACEMENT

In order for the airflow through the Uniguard to be representative of the airflow in the ventilation duct, the Uniguard should be placed as an airflow meter would be. See the installation guide supplied with the product.

You can also use national or local rules for mounting in accordance with "Methods for measuring airflow in ventilation installations".

INSTALLATION

STx pipes made of aluminium can be cut in order to adjust them to the ventilation duct. Hole size \varnothing 38 mm. For insulated, round and small ducts, mounting brackets are used and in this case, the hole size is \varnothing 51 mm.

MAINTENANCE

The detector has an intelligent control circuit. The circuit adjusts the sensitivity so the detector can function as best as possible for its entire lifetime. Once the control circuit has reached its maximum sensitivity compensation for contaminants and starts to reach a false alarm, a service alarm is indicated. The life of the smoke detector can be extended by cleaning the detector once a year using a vacuum cleaner.

AIRFLOW CONTROL

The detector has an electronic airflow control. When the detector is properly mounted, the yellow "low flow" LED goes out. This function is a simple confirmation that the airflow from the duct is actually moving through the UG8. For special mountings, the airflow control can be disabled by mounting on the jumper (factory setting) placed on the main circuit board, to the right of the reset button.

SIMPLE FUNCTION TEST

After set up, the smoke detector should be tested. The test, for example, can be carried out using our SOLO A5 test spray. Use the test hole in the cover. **Do not forget to replace the plastic plug after the test.**

NB! When mounted outdoors or in non-insulated attics, etc. where there is a risk of condensation, the detector must be insulated against the ambient air using, for example, Calectro's UG-COVER-75 protective cover. Install a sign indicating the presence of a concealed smoke detector.

FUNCTION

Normal operating

mode: During normal operations, all relays are activated and the connection chamber cover lights up green.

Smoke alarm: The detector LED lights up red.

Resetting: Press the reset button to reset the detector to normal operating mode. Alternatively, reset it using a short circuit between blocks 9 and 10.

Service alarm: When the detector detects smoke or is contaminated, the detector's LED will first light up yellow before the alarm goes off with a red light. If the detector is contaminated, a yellow light appears.

This is an optical indication (a pre-alarm or service alarm) meaning that the detector is contaminated and that it may give a false alarm in the future if it is not cleaned or replaced.

Fault:

If a failure occurs in the internal smoke detector circuit, or if the smoke detector is removed, the connection chamber cover will flash yellow for system failure and the relays for the smoke alarm, service alarm and system failure alarm will be disabled.

Low airflow:

The connection chamber cover lights up yellow (and the relays is disabled) if the air speed in the duct is low, if the UG8 is mounted at an unsuitable place in the duct or if the UG8 is very contaminated. Check that smoke detection is working by pumping smoke (i.e. from a smoke machine) into the ventilation duct and see whether the UG8 indicates a smoke alarm.

DIMENSIONS (mm)

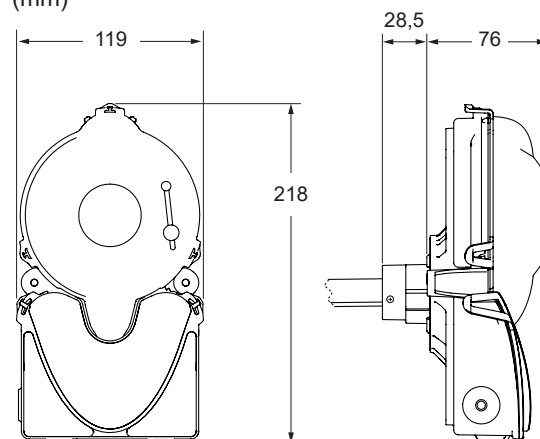

CIRCUIT DIAGRAM

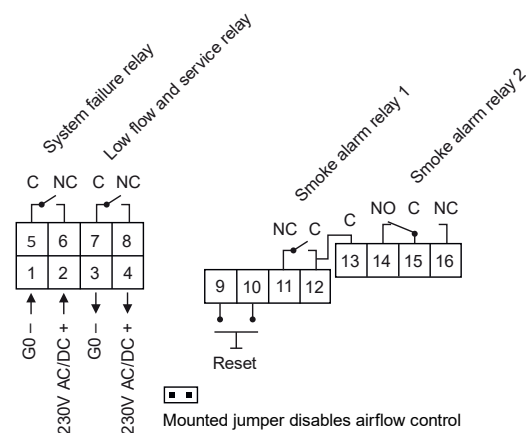

The relays are displayed in alarm mode, as they are in the event of a power outage.