



VKAP 3.0/VKA EKO

EN MOUNTING AND INSTALLATION INSTRUCTION



SYMBOLS AND MARKING

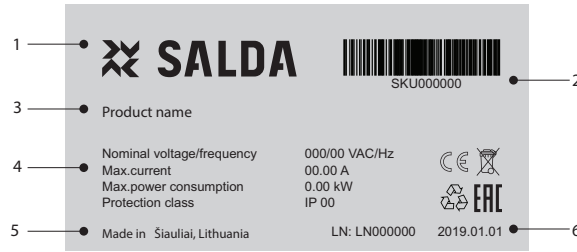

Figure 1.1 - Technical label

1 - Logo; 2 - Product code (SKU); 3 - Product name; 4 - Technical data; 5 - Production place; 6 - Lot number and production date.

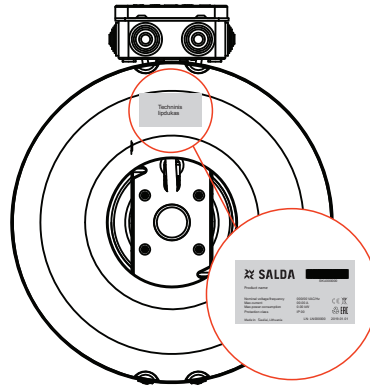

Figure 1.2 - VKAP 3.0/VKA EKO technical label place



Figure 1.3 - Indication for air flow direction.

GENERAL INFORMATION

Before installing the device be sure to read all the information contained in this document. Installation should be performed only by the trained and qualified personnel, familiar with the installation, supervision, and servicing procedures of such type of equipment and using the appropriate tools required for the installation work. If the provided information is unclear or any doubts regarding the installation and operation safety arise, please contact the manufacturer or its authorized representative. The device may be operated only in the conditions listed below. It is strictly forbidden to use the device for the purpose other than it is intended for or neglect the determined working conditions without the written permission of the manufacturer or its authorized representative. In case of malfunction it should be reported to the manufacturer or its authorized representative describing the fault and submitting the data indicated on the label of the product. In case of malfunction it is forbidden to repair, to open the device without the prior written permission of the manufacturer or its authorized representative. Opening, repair or modification of the device may be performed only after receiving the written permission of the manufacturer or its authorized representative. Before using the products manufactured or supplied by the company, the clients must ensure the products are compatible with the selected environment.

TRANSPORTATION AND STORAGE

All devices are packed in the factory in order to satisfy ordinary transportation conditions. After unpacking the device should be checked for damage. It is forbidden to install damaged devices!!! The package is only a protective measure! Upon unloading and warehousing the devices use the appropriate hoisting equipment in order to avoid damage and injuries. Do not lift the devices holding them by the power cords, connection boxes, air intake/exhaust flanges. Try to avoid smashing and crashing. Before installation store the devices in a dry place, and ensure that the relative humidity is not higher than 70% (at +20°C), and the average ambient temperature is from +5°C to +30°C. The storage place should be secured from dirt and water. During storage and transportation the devices should be placed vertically, ensuring that the connection flanges are vertically directed. The recommended warehousing period should not be longer than one year. If stored for a period that is longer than one year, before installation it should be checked if the bearings rotate easily (turning the impeller by hand).

PURPOSE OF THE DEVICE

The device is used in the ventilation and conditioning systems for the intake of the fresh air (free from chemical compounds that are apt to cause

the corrosion processes; free from agents that are aggressive to zinc, plastic, rubber; free from particles of hard, adhesive or fibre materials).

DESCRIPTION

Fan rotation speed is controlled by changing the voltage.
Bearings do not require any servicing.
Manual thermocontact motor protection.

OPERATING CONDITIONS

Units are forbidden to be used in potentially explosive environment.
Unit is designed to supply/extract only clean air from a room (free of chemical compounds causing metal corrosion, of substances aggressive to zinc, plastic and rubber, and of particles of solid, adhesive and fibred materials).
Unit shall be operated indoors only.
Maximum permissible ambient air temperature shall be considered.
Minimum permissible ambient air temperature: -40 °C.
Ventiliatorius korpusas turi būti izoliuotas izoliacine medžiaga tokia pat kaip ir izoliuojamų ortakių izoliacine medžiaga. Izoliacinės medžiagos storis ir savybės turi būti vienodos.

SAFETY MEASURES

Do not use this device for other purposes than those specifically indicated.
Do not dismantle or modify the device. This may cause a mechanical damage or even bodily injuries.
When installing and servicing the device wear a special overall. Caution! The corners and edges of the device and its parts may be sharp and cause injury.
When working near the device avoid any flaring clothing which can be caught by the operating fan.
All the products pre-packed in the factory are not entirely prepared for the operation. The devices can be operated only when connected to the ducts or after installation of the protective grating on the air intake and exhaust openings.
Do not thrust fingers or other objects into the protective grating of the intake and exhaust openings or into the connected duct. If any foreign body accidentally gets inside the device immediately disconnect it from the electric power supply. Before removing the foreign body it is necessary to ensure that all the mechanical parts of the device have stopped moving. Also make sure that there is no possibility for the device to turn on accidentally.
Avoid direct contact with the intake and exhaust air flow of the device.
Do not plug the device in any other power outlet than that indicated on the product label on the housing of the device.
Never use the power cord if it is damaged.
Never take the power cords that are plugged into the outlets if your hands are wet.
Never immerse extension cables and plugs into water.
Do not operate the device if it is mounted onto the curved stands, uneven or unstable surfaces.
Never use this device in the explosion hazard and aggressive materials containing environment.

INSTALLATION

MECHANICAL CONNECTION

Installation should be performed only by the experienced and qualified personnel.
To ensure the safe operation the installation of the device should be firm and tight.
The device is connected to the duct system.
It is necessary to provide protection against the contact with the operating fan impeller (to ensure this, special accessories should be used or appropriate duct length should be selected).
Do not connect the elbows near the connection flanges of the unit. The minimum distance of the straight air duct between the unit and the first branch of the air duct in the suction air duct must be $1xD$, in air exhaust duct $3xD$, where D is diameter of the air duct.
The fan can be mounted in any position (see Fig. #1-6).
When connecting the ducts please observe the air flow direction indicated on the housing of the device.
When mounting the fans onto the walls or ceilings it is recommended to use special supporting accessories (see Fig. #1)
When connecting the fans into the duct system it is recommended to use the accessory clamps (see Fig. #2). This will help to reduce the vibration of the device transmitted into the duct system and the environment.
It is recommended to use air filters that reduce the amount of dirt accumulating on the fan's impeller. The accumulated dirt affects the balance of the impeller which may cause vibration. This may be the reason for the improper operation of the fan motor.
If there is a possibility for condensate or water to access the unit, external protective measures shall be fitted.

#1 Mounting the device onto the wall using the supporting element

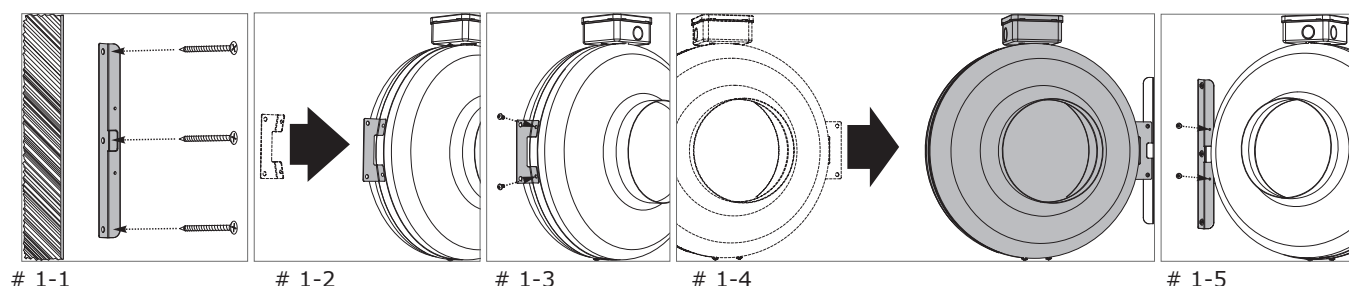

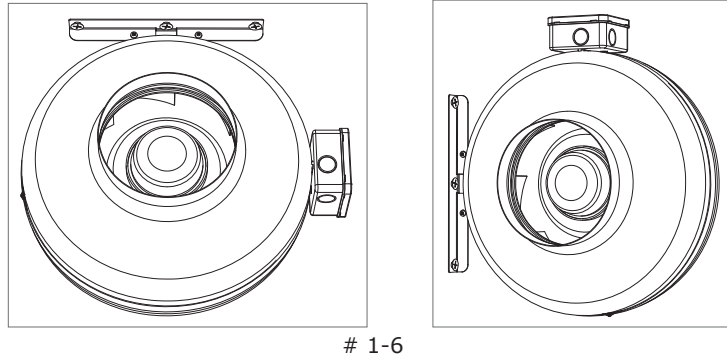

#2 Connection to the duct using the clamp

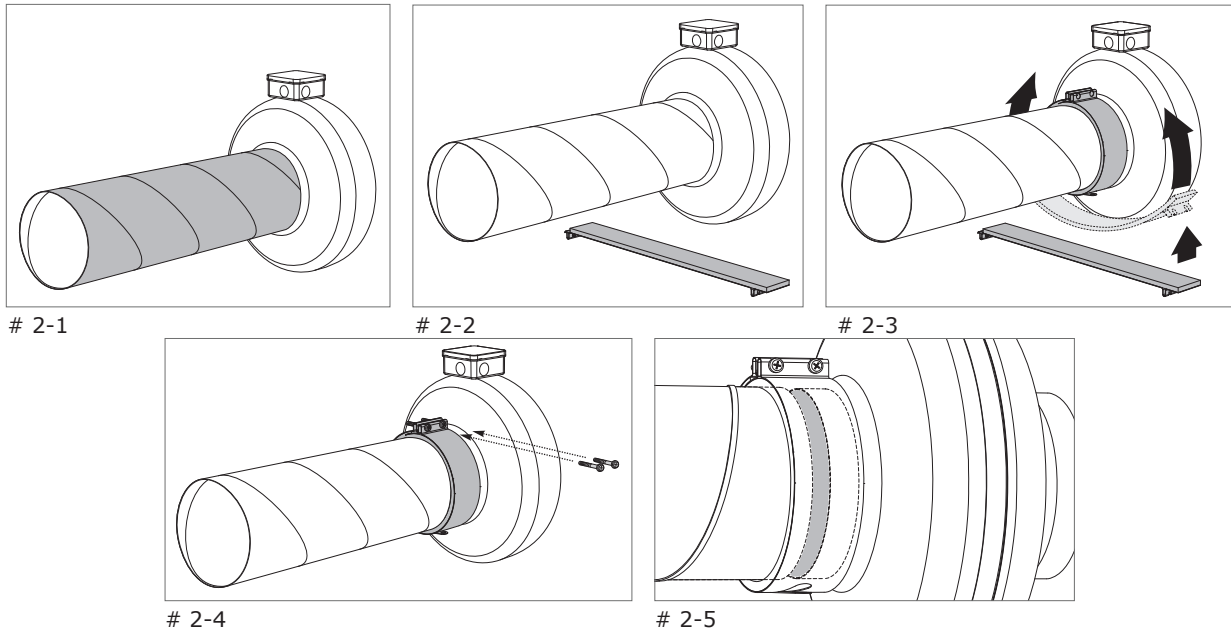

ELECTRIC INSTALLATION

The devices are equipped with rotating parts and are connected to the electric power supply. This may cause risk for human health and life. Therefore, when performing the installation, it is necessary to follow the safety requirements. If you have doubts regarding the safe installation and operation of the device, please contact the manufacturer or its authorized representative.

Installation should be performed only by experienced and qualified personnel.

Make sure that the characteristics of the power supply correspond to the information provided on the product label on the housing of the device. The selected power cable should be in accordance with the capacity of the device.

The device should be connected in accordance with the specially determined power connection scheme that is included into this document and indicated under the cover of the power connection case (see Fig. #3).

It is necessary to connect the external protective component (automatic connector or fuse) with the operating current that is 1.5 times greater than the maximum current of the device (indicated on the label of the device).

The unit must be adequately grounded.

If the device motor speed controller is used, it is necessary to make sure that it can guarantee the safe operation of the motor.

It is necessary to ensure the minimum speed of the motor that triggers the opening of the backward extract valves (if installed).

Frequency converters are not used for the speed control of these devices.

WIRING DIAGRAM

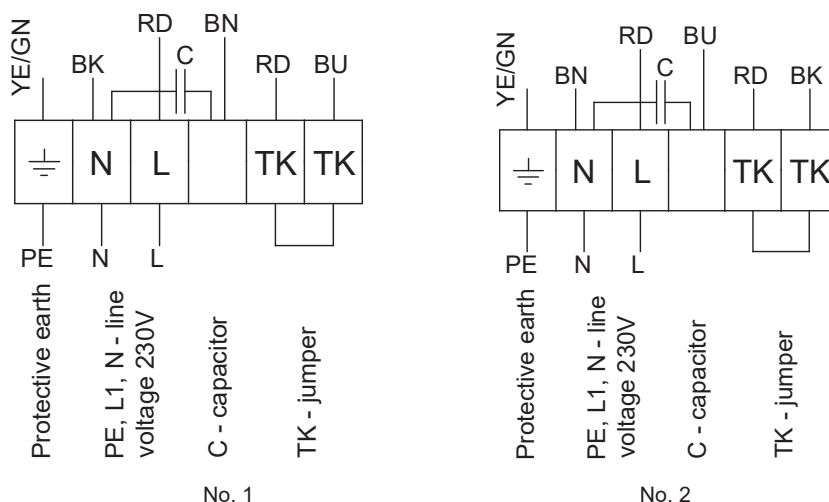

YE/GN	BU	BN	BK	RD
yellow – green	blue	brown	black	red

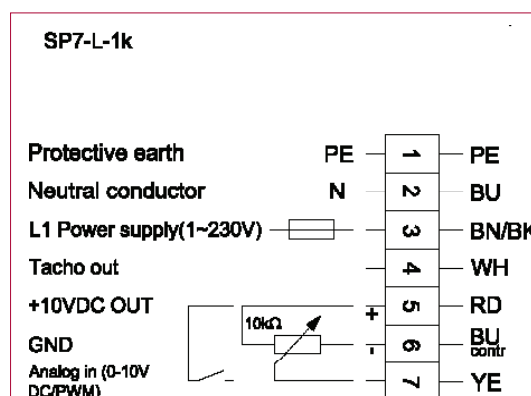

PE	BK	BU	YE	WH	RD	BN
- green - yellow	- black	- blue	- yellow	- white	- red	- brown

START-UP

The start-up should be performed only by the trained and qualified personnel.

Before starting the device it is necessary to make sure that the supply circuit corresponds to the indications on the label.

Before starting the device it is necessary to make sure that the device is connected to the power supply observing the indications of the power connection scheme that is included into this document and provided under the cover of the power connection case.

Before starting the device it is necessary to make sure that the above mentioned safety and installation requirements have been observed.

After starting the device it is necessary to make sure that the motor is rotating evenly and without vibrations, and that no unnecessary noise is heard.

After starting the device it is necessary to check whether the air flow of the device corresponds to the air flow direction(s) indicated on the housing.

It is necessary to check whether the current used by the motor does not exceed the maximum current volume (indicated on the label of the device).

It is necessary to check the motor for overheating.

It is forbidden to turn the fan on and off too often as it can cause the overheating of the motor winding or damage the insulation.

MAINTENANCE

Maintenance should be performed only by the trained and qualified personnel.

Fan bearings do not require any maintenance.

If the fan is not equipped with the air filter the only requirement for the maintenance of the fan is to clean the impeller. It is recommended that the impeller should be cleaned at least once every six months.

Before cleaning it is necessary to disconnect the supply voltage and block the switch in order to prevent the accidental start-up.

It is necessary to wait until any mechanical movements will stop, the motor will cool down and the connected capacitors will discharge.

Please make sure that the fan and its parts and accessories are mounted firmly and tightly.

The impeller should be cleaned with caution in order not to disturb the balance of the impeller.

When cleaning the impeller it is strictly forbidden to use any mechanical cleaners, chemical agents, detergents, compressed air flow and any liquids.

It is forbidden to wash the fan with any liquids.

After the maintenance procedure the device should be installed into the duct system performing the steps indicated in the installation and start-up sections and observing the requirements listed in this document.

IMPROPER OPERATION AND REPAIR

Repair works should be performed only by the trained and qualified personnel.

After turning off the device the following steps should be performed:

Check if the supply voltage and current correspond to the requirements provided on the product label.

Check if the electric current is supplied to the device.

After solving problems related with the supply of the electric current, restart the device.

If the power supply is not interrupted, but the device does not start the following steps should be performed:

Wait for 10-20 minutes until the motor cools down.

If the motor starts automatically within 10-20 minutes without disconnecting the power supply, it means that the automatic thermal protection has been turned on. It is necessary to determine the cause of the motor overheating and to eliminate the problem.

If the motor does not start within 10-20 minutes, the following steps should be performed:

Disconnect the supply voltage

Wait until any mechanical movements will stop, the motor will cool down and the connected capacitors will discharge.

Ensure that the impeller is not blocked.

Check the capacitor (for single-phase fans – according to the connection scheme). If the problem persists, replace the capacitor.

If this does not help, it is necessary to contact the supplier.

DIMENSIONS AND WEIGHT

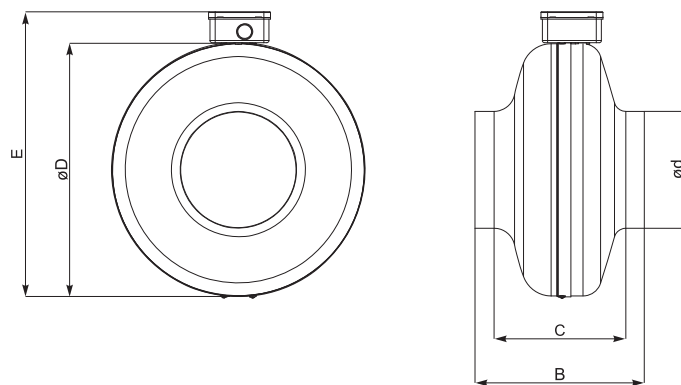

VKAP 3.0	B	C	øD	ød	E	m
	[mm]	[mm]	[mm]	[mm]	[mm]	[kg]
100 LD	189	152	244	100	287	3,0
100 MD	189	152	244	100	287	3,0
125 LD	182	143	243	125	286	3,0
125 MD	182	143	243	125	286	3,0
150 LD	217	166	344	150	387	3,0
160 LD	217	166	344	160	387	4,0
160 MD	189	143	244	160	287	4,0
200 LD	231	179	344	200	387	4,7
200 MD	219	167	344	200	387	4,0
250 LD	230	167	344	250	387	4,7
250 MD	223	160	344	250	387	4,0
315 LD	256	188	402	315	444	5,6
315 MD	243	175	402	315	444	6,0
VKA EKO	B	C	øD	ød	E	m
	[mm]	[mm]	[mm]	[mm]	[mm]	[kg]
125	207	175	245	125	290	2,1
160	200	160	245	160	290	2,2
200	240	190	345	200	390	3,7
250	245	185	345	250	390	3,6
315	250	180	400	315	445	4,6

TECHNICAL DATA

VKAP 3.0		100 LD	100 MD	125 LD	125 MD	150 LD	160LD	160 MD
- phase/voltage	[50 Hz/VAC]	~1 / 230	~1 / 230	~1 / 230	~1 / 230	~1 / 230	~1 / 230	~1 / 230
- power	[kW]	0,074	0,074	0,074	0,074	0,103	0,103	0,074
- current	[A]	0,3	0,3	0,3	0,3	0,5	0,5	0,3
- speed	[min ⁻¹]	2800	2800	2800	2750	2800	2800	2800
- capacitor	[μF]	2,0	4,0	2,0	4,0	2,0	2,0	2,0
maks. transportuojamo oro temperatūra	[C°]	-40 / 40	-40 / 40	-40 / 40	-40 / 40	-40 / 60	-40 / 60	-40 / 40
- motor protection class		IP-44	IP-44	IP-44	IP-44	IP-44	IP-44	IP-44
- wiring diagram		No. 2	No. 1	No. 2	No. 1	No. 1	No. 1	No. 1

VKAP 3.0		200 LD	200 MD	250 LD	250 MD	315 LD	315 MD
- phase/voltage	[50 Hz/VAC]	~1 / 230	~1 / 230	~1 / 230	~1 / 230	~1 / 230	~1 / 230
- power	[kW]	0,140	0,103	0,140	0,103	0,278	0,219
- current	[A]	0,6	0,5	0,6	0,5	1,2	0,9
- speed	[min ⁻¹]	2660	2796	2659	2796	2762	2704
- capacitor	[μF]	4,0	2,0	4,0	2,0	5,0	5,0
maks. transportuojamo oro temperatūra	[C°]	-40 / 60	-40 / 60	-40 / 60	-40 / 60	-40 / 50	-40 / 50
- motor protection class		IP-44	IP-44	IP-44	IP-44	IP-44	IP-44
- wiring diagram		No. 1	No. 1	No. 1	No. 1	No. 1	No. 1

VKA EKO		125	160	200	250	315
- phase/voltage	[50 Hz/VAC]	~1, 230	~1, 230	~1, 230	~1, 230	~1, 230
- power	[kW]	0,083	0,083	0,170	0,170	0,166
- current	[A]	0,88	0,88	1,59	1,32	1,56
- speed	[min ⁻¹]	3200	3200	3210	3210	2550
maks. transportuojamo oro temperatūra	[C°]	-25...+60	-25...+60	-25...+45	-25...+45	-25...+60
- motor protection class		IP-44	IP-44	IP-44	IP-44	IP-44
- wiring diagram		No. 3	No. 3	No. 3	No. 3	No. 3

ECODESIGN DATA TABLE

VKAP 3.0		100 LD	100 MD	125 LD	125 MD	150 LD	160LD	160 MD
Specific energy consumption (SEC) cold	[kWh/m ² a]	-52,1	-51,7	-52,3	-51,7	-53,1	-56,4	-52,5
Specific energy consumption (SEC) average	[kWh/m ² a]	-25,1	-24,6	-25,3	-24,6	-26,1	-26,3	-25,4
Specific energy consumption (SEC) warm	[kWh/m ² a]	-9,6	-9,1	-9,8	-9,1	-10,6	-10,8	-9,9
Declared typology		Unidirectional	Unidirectional	Unidirectional	Unidirectional	Unidirectional	Unidirectional	Unidirectional
Type of drive installed (fan)		Variable	Variable	Variable	Variable	Variable	Variable	Variable
Type of heat recovery system		N/A	N/A	N/A	N/A	N/A	N/A	N/A
Thermal efficiency of heat recovery	[%]	N/A	N/A	N/A	N/A	N/A	N/A	N/A
Maximum flow rate	[m ³ /h]	260	173	285	172	615	690	320
Electric power input of the fan drive at maximum flow rate	[W]	74	46	77	50	105	106	75
Sound power level (L _{wa})	[dB(A)]	58	46	54	42	59	57	54
Reference flow	[m ³ /s]	0,05	0,03	0,06	0,03	0,12	0,13	0,06
Reference pressure difference	[Pa]	50	50	50	50	50	50	50
SPI	[W/(m ³ /h)]	0,2	0,22	0,19	0,22	0,14	0,12	0,17
Control factor and control typology		0,65	0,65	0,65	0,65	0,65	0,65	0,65
Declared maximum internal leakage rates	[%]	N/A	N/A	N/A	N/A	N/A	N/A	N/A
Declared maximum external leakage rates	[%]	<1	<1	<1	<1	<1	<1	<1
Position and description of visual filter warning for RVU's		N/A	N/A	N/A	N/A	N/A	N/A	N/A
AEC average	[kWh]	130	146	122	147	90	79	114
AEC cold	[kWh]	130	146	122	147	90	79	114
AEC warm	[kWh]	130	146	122	147	90	79	114
AHS Average	[kWh/a]	2830	2830	2830	2830	2830	2830	2830
AHS Cold	[kWh/a]	5536	5536	5536	5536	5536	5536	5536
AHS Warm	[kWh/a]	1280	1280	1280	1280	1280	1280	1280
ErP Compliance		2018	2018	2018	2018	2018	2018	2018
Internet address for disassembly instructions								www.salda.it

VKAP 3.0		200 LD	200 MD	250 LD	250 MD	315 LD	315 MD	
Declared typology		Unidirectional	Unidirectional	Unidirectional	Unidirectional	Unidirectional	Unidirectional	
Type of drive		External MSD or VSD	External MSD or VSD	External MSD or VSD	External MSD or VSD	External MSD or VSD	External MSD or VSD	
Type of HRS		N/A	N/A	N/A	N/A	N/A	N/A	
Nominal NRVU flow rate	[m ³ /s]	0,15	0,12	0,16	0,12	0,29	0,22	
Effective electric power input	[kW]	0,13	0,1	0,13	0,11	0,24	0,22	
SFPint	[W/(m ³ /s)]	N/A	N/A	N/A	N/A	N/A	N/A	
Face velocity	[m/s]	0	0	0	0	0	0	
Normal external pressure	[Pa]	312	247	288	247	318	404	
Internal pressure drop of ventilation components	[Pa]	N/A	N/A	N/A	N/A	N/A	N/A	
Static efficiency of fans used in accordance with Regulation No 327/2011	[%]	34,9	29,7	36,3	28,4	37,7	39,8	
Declared maximum external leakage	[%]	<1	<1	<1	<1	<1	<1	
Casing sound power level (L _{wa})	[dB(A)]	56	53	54	50	53	56	
ErP Compliance		2018	2018	2018	2018	2018	2018	
Internet address for disassembly instructions								www.salda.it

VKA EKO		125	160	200	250	315
Declared typology		Unidirectional	Unidirectional	Unidirectional	Unidirectional	Unidirectional
Type of drive		Variable	Variable	Variable	Variable	Variable
Type of HRS		N/A	N/A	N/A	N/A	N/A
Nominal NRVU flow rate	[m ³ /s]	0,06	0,07	0,18	0,18	0,19
Effective electric power input	[kW]	0,08	0,07	0,17	0,17	0,16
SFPint	[W/(m ³ /s)]	N/A	N/A	N/A	N/A	N/A
Face velocity	[m/s]	0	0	0	0	0
Normal external pressure	[Pa]	364	317	350	384	381
Internal pressure drop of ventilation components	[Pa]	N/A	N/A	N/A	N/A	N/A
Static efficiency of fans used in accordance with Regulation No 327/2011	[%]	26,2	31,4	38,1	40,4	47,1
Declared maximum external leakage	[%]	<1	<1	<1	<1	<1
Casing sound power level (Lwa)	[dB(A)]	57	60	59	58	62
ErP Compliance		2018	2018	2018	2018	2018
Internet address for disassembly instructions						www.salda.it

DECLARATION OF CONFORMITY

Manufacturer

SALDA, UAB
Ragainės g. 100
LT-78109 Šiauliai, Lithuania
Tel.: +370 41 540415
www.salda.lt

Hereby confirms that the following products:

VKAP 3.0, VKA EKO

Provided it was delivered and installed in the facility in accordance with the included installation instructions, comply with all applicable requirements in the following directives and regulations:

Machinery Directive 2006/42/EC
Low Voltage Directive 2014/35/EU
EMC Directive 2014/30/EU
RoHS 2 Directive 2011/65/EU
Energy labeling of residential units Nr. 1254/2014
Ecodesign requirements for ventilation units Nr. 1253/2014
The following regulations are applied in applicable parts:

Ecodesign requirements for ventilation units Nr. 1253/2014;
Energy labeling of residential units Nr. 1254/2014.

The following harmonized standards are applied in applicable parts:

EN ISO 12100:2012 - Safety of machinery - General principles for design - Risk assessment and risk reduction.
EN 60335-1:2012 - Household and similar electrical appliances. Safety. Part 1: General requirements.
EN 60529:1999/A2:2014/AC:2019 - Degrees of protection provided by enclosures (IP code).
EN 60204-1:2018 - Safety of machinery - Electrical equipment of machines - Part 1: General requirements.
EN IEC 61000-6-1:2019-03 - Electromagnetic compatibility (EMC) -- Part 6-1: Generic standards - Immunity for residential, commercial and light-industrial environments.
LST EN 61000-6-2:2019 - Electromagnetic compatibility (EMC) -- Part 6-2: Generic standards - Immunity for industrial environments.
LST EN 61000-6-3:2008 - Electromagnetic compatibility (EMC) -- Part 6-3: Generic standards - Emission standard for residential, commercial and light-industrial environments.

Should any alterations be made in the products, this declaration will no longer apply.

Quality: Salda UAB activities are in line with the international quality management system standard **ISO 9001:2015**.

Date 2020-11-02



Giedrius Taujenis
Director product development

WARRANTY

1. All equipment manufactured in our factory is checked in operating conditions and tested before delivery. Test protocol is supplied together with the unit. The equipment is shipped in good working order and condition to the direct client. The unit is warranted for the period of 24 months from the invoice date.
2. If equipment is found to have been damaged during transportation, a claim should be made against carrier, as we assume no responsibility for such damage.
3. This warranty does not apply:
 - 3.1. when transportation, storage, installation and maintenance instructions of the unit are violated;
 - 3.2. when the equipment is improperly maintained, mounted - inadequate maintenance;
 - 3.3. when the equipment without our knowledge and permission has been upgraded or unskilled repairs were made;
 - 3.4. when the unit was used not for its original purpose.
 - 3.5. Company SALDA UAB is not responsible for potential loss of property or personal injury in cases where AHU is manufactured without a control system and the control system will be installed by the client or third parties. The manufacturer's warranty does not cover devices that will be damaged by installing the control system.
4. This warranty does not apply at these malfunction cases:
 - 4.1. mechanical damage;
 - 4.2. damage caused by entering outside objects, materials, liquids;
 - 4.3. damage caused by natural disaster, accident (voltage change in the electricity network, lightning, etc..).
5. The company assumes no liability for its products either directly or indirectly damage, if the damage is caused by failure to comply with installation and mounting regulations, deliberate or careless users or third-party behavior.

These conditions are readily discernable when the equipment is returned to our factory for inspection.

If the direct client determines that equipment is found to be faulty, or a breakdown occurred, he should inform the manufacturer within five working days and deliver the equipment to manufacturer. Delivery costs should be covered by customer.



Manufacturer reserves the right to change this technical passport any time without prior notice, if some typographic errors or inaccurate information is found, as well as after improving the apps and/or the devices. Such changes will be included in the new issues of the technical passport. All illustrations are just for information and thus may differ from the original device.

20.1. LIMITED WARRANTY COUPON

Warranty term

24 months warranty*

I received complete package and technical manual of the product ready for usage. I have read warranty terms and conditions and agree with them:

.....
Customer's signature

*refer to WARRANTY CONDITIONS

Dear User, we appreciate your choice and do hereby guarantee that all ventilation equipment manufactured by our Company is inspected and thoroughly tested. An operational and high-quality product is sold to the direct buyer and shipped from the territory of the factory. It is provided with a 24-month warranty since invoice issue date.

Your opinion is important to us, thus we always look forward to hearing your comments, feedback, or suggestions regarding technical and operational characteristics of the Products.

In order to avoid any misunderstandings, please read the instructions for installation and operation of the product as well as other technical documents of the product carefully. The number of the Limited Warranty Coupon and serial number of the product specified on the silver identification sticker attached to the housing must match.

The Limited Warranty Coupon shall be valid provided that the seller's stamps and records are clear. It is prohibited to change, delete, or rewrite the data specified on it in any manner – such a coupon shall be invalid.

With this Limited Warranty Coupon the manufacturer confirms one's obligations to implement the imperative requirements established by effective laws on protection of consumer rights in the event of identification of any defects of the products.

The manufacturer reserves the right to refuse provision of free warranty servicing in cases when the warranty conditions listed below are disregarded.

UNIT'S MAINTENANCE TABLE

Product name*		
lot number*		
Instalation	Interval	Date
Fan cleaning	Once a year**	_____
Heat exchanger cleaning	Once a year**	_____

Filter replacement	Every 3-4 months**	_____

* - Look at the product label.
** - At least.

NOTE. The purchaser is required to fill in the "Product maintenance table".



MAN000147

